

If it Filters we probably have it



Liquid Filters



Air Filtration (HVAC)



Metal Washable Filters



**Bulk Filter Media Rolls
& Cut Pads**



Odor and Fume Control



**Rotating Equipment &
Reverse Pulse Dust
Collector Cartridges**



**Paint Booth Filtration
Liquid or Powder Paint**



**Industrial Filter
Housings**

Filters-ALF

20150 Kuykendahl Rd. #200

Spring, TX 77379

713-253-0100

Table of Contents

Page

2-33 Liquid Filters

34-51 Liquid Housings

52 Liquid Strainer baskets

53-57 Fume,Vapor & Air Pollution Control Equipment

58-81 Activated Carbon, Molecular filtration

 Disposable and Refillable trays & Cartridges

82-99 Gas Turbine Filters & Dust Collector filters

100-101 Engines compressors & blowers filters & Housings

102 Air/oil Separators for Compressors

103-111 HEPA's, HVAC and general filtration

112 Paint Booth filters

113-117 Air Filter Housings

118-119 Custom Filters

120-132 Competitive brands that we offer replacements for

Quick Reference Guide

Liquid Filters | **Food & Beverage/High Purity Water/Drinking water**

PRODUCTS-Applications

Liquid Filters

Food & Beverage / High Purity Water and Drinking Water

Complete line of absolute rated membrane filter elements for your most demanding applications; we can also custom manufacture for your systems and applications up to 40 inches in length

CLS helps you meet today's regulatory requirements and provide fresh drinking water to satisfy growing population needs and water shortages. CLS's filter cartridges and housings are designed to ensure your process will continue to provide fresh drinking water by eliminating sediment and other impurities. CLS continues to develop new and innovative products to meet the challenges in cost effective filtration

RELATED PRODUCTS



Liquid Filter Bags



Stainless Steel Cartridges



Standard Efficiency Pleated Cartridges



Melt Blown Cartridges



String Wound Cartridges



High Efficiency Pleated Cartridge



Nylon 6,6 Membrane Cartridges



Polyethersulfone Membrane Cartridges



PTFE Membrane Cartridges



Carbon Cartridges

RELATED PRODUCTS



Nylon 6,6 Membrane Cartridges



Polyethersulfone Membrane Cartridges



PTFE Membrane Cartridges



Melt Blown Cartridges



String Wound Cartridges



High Efficiency Pleated Cartridge



Carbon Cartridges



Liquid Filter Bags



POEL Extended Life Bag



625 HF Series High Flow Cartridges

NYLON 6,6 MEMBRANE CARTRIDGES

*NY Series for DI water, process filtration,
chemical, electronics & beverages*

FEATURES AND SPECIFICATIONS

- Nylon 6,6 cartridges offer a wide array of micron ratings from .03 to 20 microns
- All Nylon 6,6 are produced in-house on the most modern equipment available
- Complete in-house testing guarantees a superior and consistent product
- We offer all end cap configurations to provide the proper cartridge to fit your applications and housing
- All Nylon 6,6 membrane elements are internally supported offering strength to prevent media failure
- Cartridges have excellent dirt holding capacity with low flow resistance
- All media materials used in production are FDA Title 21 compliant
- End caps are thermally welded with no additives
- Cartridges are constructed in a clean room environment
- Naturally hydrophilic media does not need to be wetted before use
- Cartridges may be ordered as final rinsed with 18 mega ohm water



Toxicity	Purity
Cartridges are manufactured with no additives or other manufacturing agents. We guarantee all materials used in the production meet FDA Title 21 of the Code of Federal Regulations 174.5 and 177.1520.	Cartridges are Free of Surfactants, Resins, Binders and Adhesives
Sterilization	
Multiple Autoclaving for 30 Minutes at 250°F (121°C) under no End Load Conditions. In-line Steam Sterilization is not recommended. May be In-line Sanitized with Hot Water at 180°F (82°C) for 1 hour.	

Product Specifications	
Retention Ratings:	.03, .1, .2, .45, .65, .8, 1.2, 5, 10 & 20 micron
Membrane:	Nylon 6,6
Support Media:	Polypropylene
End Caps:	Polypropylene
Center Core:	Polypropylene
Outer Support Cage:	Polypropylene
Maximum Operating Temperature:	175°F
Nominal Diameter:	O.D. - 2.65" I.D. - 1" center
Lengths:	10, 20, 30, & 40 inch
Maximum Differential Pressure:	45 psid

AVAILABLE END CAPS



226

222

DOE Gasket

Fin

Closed

BUILDING A PART NUMBER

NYLON 66	MICRON		CARTRIDGE LENGTH	CORE MATERIAL	END CAP	GASKET / O-RING	18 MEGA OHM RINSE
NY	1		3	E	2	B	R
NY	.03	.8	3 = 10	E = Polypropylene	2 = 222/Fin	B = Buna V = Viton® T = Teflon® S = Silicone N = Neoprene D = EPDM	R
	.1	1.2	5 = 20		4 = 222/Closed		
	.2	5.0	7 = 30		5 = 226/Closed		
	.45	10.0	9 = 40		6 = 226/Fin		
	.65	20.0			9 = DOE Gasket		

POLYETHERSULFONE MEMBRANE CARTRIDGES

*PES SERIES FOR ELECTRONICS, DI WATER,
CHEMICAL & BEVERAGE FILTRATION*

FEATURES AND SPECIFICATIONS

- (PES), Polyethersulfone cartridges offer a wide array of micron ratings from .1 to 5 microns
- All Polyethersulfone cartridges are produced in-house on the most modern equipment available
- Complete in-house testing guarantees a superior and consistent product
- Cartridges have excellent dirt holding capacity with low flow resistance
- Naturally hydrophilic media does not need wetted before use
- We offer all end cap configurations to fit your applications and housings
- Polyethersulfone media is excellent for its low protein binding and chemical compatibility
- Cartridges are manufactured to meet FDA Title 21 for food contact applications
- Cartridges are constructed in a clean room environment
- Cartridges may be ordered as final rinsed with 18 mega ohm water



Toxicity	Purity
Cartridges are manufactured with no additives or other manufacturing agents. We guarantee all materials used in the production meet FDA Title 21 of the Code of Federal Regulations 174.5 and 177.1520.	Cartridges are Free of Surfactants, Resins, Binders and Adhesives
Sterilization	
Multiple Autoclaving for 30 Minutes at 250°F (121°C) under no End Load Conditions. In-line Steam Sterilization is not recommended. May be In-line Sanitized with Hot Water at 180°F (82°C) for 1 hour.	

Product Specifications	
Retention Ratings:	.1, .22, .45, .6, .8, 1.2, & 5 micron
Membrane:	Polyethersulfone
Support Media:	Polypropylene
End Caps:	Polypropylene
Center Core:	Polypropylene
Outer Support Cage:	Polypropylene
Maximum Operating Temperature:	175°F
Nominal Diameter:	O.D. - 2.65" I.D. - 1" center
Lengths:	10, 20, 30, & 40 inch
Maximum Differential Pressure:	45 psid

FDA compliance under Title 21 of the code of federal regulations for food contact applications

AVAILABLE END CAPS



226

222

DOE Gasket

Fin

Closed

BUILDING A PART NUMBER

POLYETHERSULFONE	MICRON	CARTRIDGE LENGTH	CORE MATERIAL	END CAP	GASKET / O-RING	18 MEGA OHM RINSE
PES	.1	3	E	2	B	R
PES	.1 .22 .45 .60 .80 1.2 5.0	3 = 10 5 = 20 7 = 30 9 = 40	E = Polypropylene	2 = 222/Fin 4 = 222/Closed 5 = 226/Closed 6 = 226/Fin 9 = DOE Gasket	B = Buna V = Viton® T = Teflon® S = Silicone N = Neoprene D = EPDM	R

PTFE MEMBRANE CARTRIDGES

*PTF Series for chemical and vent filtration
with optimal air or gas flow*

FEATURES AND SPECIFICATIONS

- PTFE membrane filters offer a wide array of micron ratings from .02 to 5 microns
- Excellent for chemical and pharmaceutical filtration applications
- PFE cartridges are hydrophobic, resisting water while offering excellent air and gas flow
- All PTF cartridges are produced in-house on the most modern equipment available
- Complete in-house testing guarantees a superior and consistent product
- Multiple end cap configurations to provide the proper cartridge to fit most applications and housings
- All media materials used in production are FDA Title 21 compliant
- Cartridges are constructed in a clean room environment
- Cartridges offer structural stability, long life, and high performance with maximum filtration area



Toxicity	Purity
Cartridges are manufactured with no additives or other manufacturing agents. We guarantee all materials used in the production meet FDA Title 21 of the Code of Federal Regulations 174.5 and 177.1520.	Cartridges are Free of Surfactants, Resins, Binders and Adhesives
Sterilization	
Multiple Autoclaving for 30 Minutes at 250°F (121°C) under no End Load Conditions. In-line Steam Sterilization is not recommended. May be In-line Sanitized with Hot Water at 180°F (82°C) for 1 hour.	

Product Specifications	
Retention Ratings:	.02, .05, .1, .2, .45, 1.0, 3.0 & 5.0 micron
Membrane:	PTFE
Support Media:	Polypropylene
End Caps:	Polypropylene
Center Core:	Polypropylene
Outer Support Cage:	Polypropylene
Maximum Operating Temperature:	180°F
Diameter:	O.D. - 2.65" I.D. - 1" center
Lengths:	10, 20, 30, & 40 inch
Maximum Differential Pressure:	45 psid

AVAILABLE END CAPS



226

222

DOE Gasket

Fin

Closed

BUILDING A PART NUMBER

PTFE	MICRON		CARTRIDGE LENGTH	CORE MATERIAL	END CAP	GASKET / O-RING	18 MEGA OHM RINSE
PTF	.02		3	E	2	B	R
PTFE	.02	.45	3 = 10	E = Polypropylene	2 = 222/Fin	B = Buna V = Viton® T = Teflon® S = Silicone N = Neoprene D = EPDM	R
	.05	1.0	5 = 20		4 = 222/Closed		
	.1	3.0	7 = 30		5 = 226/Closed		
	.2	5.0	9 = 40		6 = 226/Fin 9 = DOE Gasket		



"BE" MELT BLOWN CARTRIDGES
QUAD SERIES
MELT BLOWN FILTERS
100% MADE IN THE U.S.A.

QUAD-PRO

- FDA Title 21 Compliant
 - Great Value
 - No Glue or Binders
 - High Dirt Loading
 - Low Pressure Drop
-

QUAD-DELUXE

- 95% Efficiency at designated microns
 - FDA Title 21 Compliant
 - Integrated 4 Stage Depth Loading
 - High Dirt Loading
 - Low Pressure Drop
-

QUAD-ELITE

- 99% Efficiency at designated microns
 - FDA Title 21 Compliant
 - Integrated 4 Stage Depth Loading
 - Cored Center for Filter Stability
 - High Dirt Loading
 - Heat set surface to stop fiber migration
-

QUAD-RO

- High-End Membrane Protection when it is Critical
- FDA Title 21 Compliant
- Integrated 4 Stage Depth Loading
- Cored Center for Filter Stability
- High Dirt Loading
- No Fiber Migration



"BE" Melt Blown Cartridges are WQA C USA
tested and certified to:
NSF/ANSI 372 / NSF/ANSI 61 / CSA B483.1
NSF/ANSI 42 - Component



The 4-zone technology allows the larger particles to be trapped in the outer most layers. The inner most layer is where the true efficiency rating is achieved. The two images show how there is a consistent dirt loading pattern throughout the life of the filter.



Zone 1
Filter Media

Zone 2
Prefilter

Zone 3
Dirt Loading

Zone 4
Dirt Loading/Open Fiber Finish

This image shows the Quad Series cut away layer by layer. The outermost layers are made of larger diameter fibers to allow larger particles to flow through, while the inner most layers trap the fine particles maximizing the life of the filter.

The Quad Series is offered with or without a heavy duty polypropylene core.



ADVANTAGES

- Removal from 1um to 100um
- Quad Zone technology allow the formation of 4 separate filtration zones within the depth of the filter cartridge.
- Continuous 4-zone structure provides effective pre-filtration and final filtration.
- State of the art computer controlled manufacturing process delivers an extremely accurate and consistent product per each zone for proper fiber sizing.
- High-strength polypropylene core maximizes flow and optimizes each of the 4 zones. If required all Quad series may be ordered with cores.
- 100% polypropylene construction allows a wide range of uses, including FDA compliant material for food and beverage contact under CFR Title 21.
- All Quad Series cartridges are free of surfactants, binders or adhesives of any kind.
- Continuous lengths up to 72" .
- All End Configurations available to fit most industry standards.
- All end caps are thermal bonded, no glues or adhesives are used.

"BE" Melt Blown Cartridges are WQA tested and certified to:
NSF/ANSI 372 / NSF/ANSI 61 / CSA B483.1
NSF/ANSI 42 - Component



C USA

STRING WOUND CARTRIDGES

*W & WQ Series with Leading-Edge
Depth Loading Technology*



FEATURES AND SPECIFICATIONS

- string wound elements are manufactured in-house on custom, high-speed, computer controlled machines for consistent thread spacing
- Customized patterns and spacing offered to adapt to your specialized applications
- Ink and paint elements have a 3-stage multi pattern winding process offering true depth loading and prevents core blinding
- With 6 media selections and 15 micron ratings, we are sure to produce the element you require
- All end cap configurations available to fit your existing housing
- Standard diameters are 2.5 and 4.5 inches
- Standard lengths from 9.75 to 40 inches
- FDA Title 21 Compliant Media



C USA

"WS" String wound cartridges are
Tested and Certified by WQA to:
NSF/ANSI 61, NSF/ANSI 42 - Component,
NSF/ANSI 372, CSA 483.1

Media	Maximum Temperature	Applications
N – Natural Cotton	300°F / 150°C	Same (non-FDA) applications as bleached cotton.
C – Bleached Cotton FDA	300°F / 150°C	For potable liquids, vegetable oils, beverages, organic solvents, water, dilute acids, petroleum oils and other services.
P – Polyester	250°F / 121°C	Chemical compatibility similar to cotton and polypropylene. Has a higher temperature resistance than polypropylene in most cases.
E – Polypropylene	180°F / 82°C	Filtration of organic acids, alkalis, solvents and many other chemicals. Very effective in low viscosity solutions.
S – Polypropylene FDA	180°F / 82°C	Same chemical compatibility as polypropylene but complies with FDA regulations that permit contact with food and edible products.
R – Rayon	300°F / 150°C	Chemical compatibility similar to cotton. Used primarily in filtration of petroleum oils.
Cores	Maximum Temperature	Characteristics
E – Polypropylene FDA	180°F / 82°C	For lower temperature applications of corrosive fluids and gases. Easily incinerated to a trace of ash.
S – Tinned Steel	375°F / 191°C	General purpose applications
4 – 304 Stainless Steel	750°F / 399°C	For high temperature dilute acids and moderately corrosive fluids.
6 – 316 Stainless Steel	750°F / 399°C	For high temperature applications and highly corrosive fluids.
Gaskets & O-Rings	Maximum Temperature	Characteristics
B – Buna	300°F / 149°C	Very good resistance to water, alkalis and many acids. Poor resistance to oils, gasoline and most solvents (except oxygenated).
V – Viton®	450°F / 232°C	Can be used at high temperature with many fuels, lubricants, hydraulic fluids and solvents.
T – Teflon®	500°F / 260°C	Excellent resistance to almost all chemicals and solvents. Good heat resistance, exceptionally good low-temperature properties.
S – Silicone	600°F / 316°C	Excellent heat resistance. Fair water resistance, poor resistance to steam at high pressures. Fair to good acid and alkali resistance, poor resistance to oils and solvents.
N – Neoprene	250°F / 121°C	Good resistance to non-aromatic petroleum, fatty oils, solvents (except aromatic, chlorinated or ketone types). Good water and alkali resistance, fair acid resistance.
E – EPDM	300°F / 149°C	Very good water resistance. Excellent resistance to oils and gasoline. Fair to good resistance to acids and alkalis.

AVAILABLE END CAPS



BUILDING A PART NUMBER

STRING WOUND	MEDIA	MICRON	CARTRIDGE DIAMETER	CARTRIDGE LENGTH	CORE MATERIAL	CORE COVER	POLYPROPYLENE END CAP	GASKET / O-RING
W	P	10	S	3	E	X	1	
W = Standard ✓ WQ = Ink & Paint	N = Natural cotton C = Bleached cotton FDA P = Polyester E = Polypropylene S = Polypropylene FDA ✓ R = Rayon	.5 30 1 50 3 75 5 100 10 125 15 150 20 200 25	S = 2.5" Standard M = 4.5" * C = Custom	1 = 9.875 2 = 9.75 3 = 10 4 = 19.5 5 = 20 6 = 29.25 7 = 30 8 = 39 9 = 40	E = Polypropylene ✓ T = Tinned Steel 4 = 304 SS 6 = 316 SS	X = No cover ✓ E = Polypropylene P = Polyester N = Nylon S = Custom	1 = DOE/no caps ✓ 2 = 222/Fin ✓ 3 = 222/Spring ✓ 4 = 222/Closed ✓ 5 = 226/Closed 6 = 226/Fin 7 = 226/Spring 8 = SOE/Spring ✓ 9 = DOE Gasket ✓ A = Custom E = Core Extender ES = Core Extender/Spring	DOE = No selection req. B = Buna ✓ V = Viton® T = Teflon® S = Silicone ✓ N = Neoprene D = EPDM

* For the 4.5" diameter cartridge, only DOE end caps are available, *Combinations are tested and certified by WQA.



"WS" String wound cartridges are Tested and Certified by WQA to: NSF/ANSI 61, NSF/ANSI 42 - Component, NSF/ANSI 372, CSA 483.1

HIGH EFFICIENCY PLEATED CARTRIDGES

H & NH Series in 2 efficiency grades, offer the ultimate in high-end filtration

FEATURES AND SPECIFICATIONS

- offers the highest grade, 90% and 99.98% efficient Cartridges on the market today
- Our media is manufactured in-house under strict guidelines to ensure consistency
- Complete in-house testing with a Capillary Flow Porometer guarantees a superior and consistent product
- With 8 micron ratings and multiple lengths to ensure we produce the element you require
- Cartridges have thermally bonded end caps and ultrasonic welded media seams for a one piece construction
- The maximum amount of media is installed in each filter without pleat blinding for increased dirt loading capacity
- Cartridges are 100% polypropylene—media, inner and outer supports and end caps
- All media and materials used in production are FDA Title 21 compliant
- Cartridges are constructed in a clean room environment
- Cartridges may be ordered with a final rinse of 18 mega ohm water
- Final, one piece construction up to 40" long ensures zero bypass



Materials of Construction		Dimensions (nominal)	
Filter Media:	Polypropylene Melt Blown	Outside Diameter:	2.65"
Hard Outer Cage:	Polypropylene	Lengths:	10", 20", 30" & 40"
Netted Outer Cage:	Polypropylene	Lengths:	9.75", 10", 19.5", 20", 29.25", 30", 39" & 40"
Support Material:	Polypropylene		
Sealing:	Thermal Bond		
Gaskets/O-Rings:	Buna N, Viton®, Teflon®, Silicone, Neoprene & EDPM		
Surface Area		Performance Specifications	
Up to 5.5ft ² (.23m ²) of Effective Filtration Area per 10" equivalent, dependent upon micron rating		Retention Ratings of 90% and 99.98% at: .2, .45, 1, 3, 5, 10, 25, & 50 micron	
Operating Conditions		FDA Listed Materials	
Maximum Differential Pressure: 35 psid @ 180°F (49°C)		Manufactured from materials which are FDA listed for food contact applications in Title 21 of the U.S. code of federal regulations	
Toxicity		Purity	
Cartridges are manufactured with no additives or other manufacturing agents. We guarantee all materials used in the production meet FDA Title 21 of the Code of Federal Regulations 174.5 and 177.1520.		Cartridges are Free of Surfactants, Resins, Binders and Adhesives	
Sterilization			
Multiple Autoclaving for 30 Minutes at 250°F (121°C) under no End Load Conditions. In-line Steam Sterilization is not recommended. May be In-line Sanitized with Hot Water at 180°F (82°C) for 1 hour.			

AVAILABLE END CAPS



BUILDING A PART NUMBER

HIGH EFF. PLEATED CARTRIDGE	MEDIA	EFFICIENCY	MICRON	CARTRIDGE LENGTH	END CAP	GASKET / O-RING	18 MEGA OHM RINSE
H	E	A	1	5	3	B	R
H = Hard Cage NH = Netted Cage	E = Polypropylene	A = 90% B = 99.98%	.2 .45 1 3 5 10 25 50	2 = 9.75 (2) 3 = 10 4 = 19.5 (2) 5 = 20 6 = 29.25 (2) 7 = 30 8 = 39 (2) 9 = 40	1 = DOE/Plastisol (2) 2 = 222/Fin 3 = 222/Spring 4 = 222/Closed 5 = 226/Closed (1) 6 = 226/Fin (1) 7 = 226/Spring (1) 8 = SOE/Spring 9 = DOE Gasket A = Custom	B = Buna V = Viton® T = Teflon® S = Silicone N = Neoprene D = EPDM	R

(1) Available in Hard Cage Only (2) Available in Netted Cage Only

STANDARD EFFICIENCY PLEATED

SE & SC Series for Cost Effective Filtration Applications



C USA
"SE" Standard Efficiency Pleated
are WQA tested and certified to:
NSF/ANSI 372, NSF/ANSI 61,
CSA B483.1, NSF/ANSI 42
(Material Safety)

FEATURES AND SPECIFICATIONS

- standard efficiency pleated cartridges are manufactured in-house offering 2 grades of media—polypropylene and polyester
- Complete in-house testing guarantees a superior and consistent products
- With 7 micron ratings, 3 standard diameters and 9 standard lengths we are sure to produce the element you require
- We produce our own molds for the PVC end caps, custom sizes and applications are welcomed
- Platisol end caps allow for high temperature resistance applications
- All seams are 100% ultrasonically welded to ensure zero bypass
- Standard diameters are 2.5, 2.75 and 4.5 inches
- Standard lengths up to 40 inches
- We place a maximum amount of media in each filter without pleat blinding for increased dirt holding capacity
- All media materials used in production are FDA Title 21 compliant
- Color coded end caps for easy micron rating identification

Materials of Construction		Dimensions (nominal)	
Filter Media:	Polypropylene or Polyester Non-woven	Outside Diameter:	2.5", 2.75", 4.5"
Sealing:	Thermal Bond	Lengths:	9.75", 9.875", 10", 19.5", 20", 29.25" 30", 39" & 40"
Surface Area		Performance Specifications	
Up to 5.5ft ² (.23m ²) of Effective Filtration Area per 10" equivalent, dependent upon micron rating		Retention Ratings: 1, 5, 10, 20, 30, 40 & 50 micron	
Operating Conditions		FDA Listed Materials	
Maximum Differential Pressure: 35 psid @ 120°F (49°C)		Manufactured from materials which are FDA listed for food contact applications in Title 21 of the U.S. code of federal regulations	

BUILDING A PART NUMBER

STANDARD EFFICIENCY PLEATED CARTRIDGE	MEDIA	CORE	CARTRIDGE DIAMETER	MICRON	CARTRIDGE LENGTH	END CAPS
S	E	E	S	1	5	1
S	E = Polypropylene C = Polyester	E = Polypropylene C = Custom	S = 2.5" standard B = 2.75" M = 4.5" C = Custom	1 5 10 20 30 40 50	1 = 9.875 2 = 9.75 3 = 10 4 = 19.5 5 = 20 6 = 29.25 7 = 30 8 = 39 9 = 40	1 = DOE/plastisol A = Custom

OEM APPLICATIONS

- AMBF has the capabilities to manufacture our standard grade filter elements to your specifications and housing requirements
- With our full line of production equipment, we have the ability to make filters up to 16 inches in diameter and 40 inches in length
- We custom laminate, pleat and apply plastisol end caps to your specifications



C USA
 "SE" Standard Efficiency Pleated are WQA tested and certified to:
 NSF/ANSI 372, NSF/ANSI 61,
 CSA B483.1, NSF/ANSI 42
 (Material Safety)

CTO CARBON BLOCK CARTRIDGES

FEATURES AND SPECIFICATIONS

- Proprietary Carbon Blend Formulations Used for Maximum Adsorption
- Cartridges will reduce Foul Odors, Chlorine Taste and Particulate Matter
- Polypropylene Outer Prefilter
- Consistent density for controlled flow rates and pressure loss
- Polypropylene or Colored Plastisol End Caps Available
- No GAC By-pass or Fluidizing
- All materials used in production are FDA Title 21 compliant
- Available up to 40" Lengths in 2.5" & 4.5" Outside Diameter
- Multiple Micron Ratings Available
- One Piece Carbon Block Construction Reduces Bypassing
- Extruded coconut carbon construction
- Plastisol end caps available for increased chemical and temperature resistance



Product Specifications	
Micron Ratings:	1, 3, 5, 10 micron
Construction:	Carbon & Polypropylene
End Caps:	Polypropylene
Operating Temperature:	Cold or ambient water use only
Diameter	O.D. - 2.65" to 4.5" I.D. - 1.1" Center
Nominal Lengths	9.75" to 40"
Chlorine & Odor Reduction Capacity @ Flow	> 6,100 gal @ 1.0 GPM *
Initial Differential Pressure @ Flow	< 3 PSID @ 1 GPM *
*Based on Manufacturer's Internal Testing	
FDA compliance under Title 21 of the code of federal regulations for food contact applications	

BUILDING A PART NUMBER

CARBON BLOCK	MEDIA	MICRON	DIAMETER	LENGTH	ELEMENT GRADE	END CAP	O-RING
CB	E	1	S	2	S		B
CB	E = Polypropylene	1 3 5 10	S = 2.5" Standard M = 4.5"	1 = 9.875 2 = 9.75 3 = 10 4 = 19.5 5 = 20 6 = 29.25 7 = 30 8 = 39 9 = 40 C=custom	S = Standard	1 = DOE-Plastisol 2 = 222/Fin 3 = 222/Spring 4 = 222/Flat 5 = 226/ Flat 6 = 226/Fin 7 = 226/Spring 8 = SOE/Spring 9 = DOE Gasket A = Custom	B = Buna V = Viton® T = Teflon® S = Silicone N = Neoprene D = EPDM

STAINLESS STEEL CARTRIDGES

M Series Cartridges for High Temperature Filtration

FEATURES AND SPECIFICATIONS

- stainless steel cartridge filters are produced with the highest quality materials in the USA, offering you the best filters for high temperature applications—up to 525°F
- Cartridges are produced in 304 and 316 stainless steel with welded and crimped construction
- Retention ratings range from 5 to 840 micron
- With 8 different lengths and 6 different end cap configurations, we are sure to produce the element you require
- Very high flow rates in both cylindrical and pleated designs
- Heavy duty construction allows for very high differential pressures; up to 60 PSID
- Low differential pressure allows filtration of very viscous solutions
- Cartridges may be cleaned for extended life



APPLICATIONS

- Straining
- Viscous Solutions
- High Temperature
- Caustic Fluids
- Hydraulic Oil
- Electronics
- Cleanable Filter
- Wastewater
- Harsh Chemicals
- High Differential Pressure
- Plating Solutions
- Adhesives

PRODUCT SPECIFICATIONS

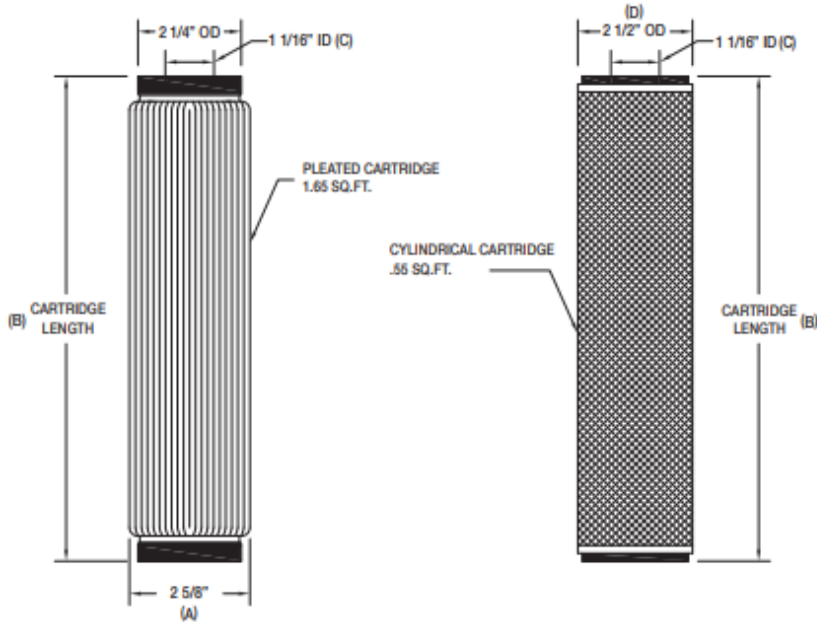

Dimensions	
A	2 5/8"
B	SEE BELOW
C	1 1/16"
D	2 1/2"

AVAILABLE END CAPS



recommends not to flow more than 10 gpm per 10" cartridge at 40 microns and lower.

BUILDING A PART NUMBER

STAINLESS STEEL CARTRIDGE	MATERIAL	MICRON		CARTRIDGE LENGTH (B)	STYLE	END CAP	GASKET / O-RING
M	4	10	3	C	1	B	
M	4 = 304 6 = 316	5	150	2 = 9.75	C = Cylindrical P = Pleated	1 = DOE (gasket)	B = Buna V = Viton® T = Teflon® S = Silicone N = Neoprene D = EPDM
		10	190	3 = 10		4 = 222/Closed	
		20	230	4 = 19.5		5 = 226/Closed	
		40	280	5 = 20		M = 1" NPTM	
		75	370	6 = 29.25		F = 1" NPTF	
		100	540	7 = 30		A = Custom	
		120	840	8 = 39			
				9 = 40			
				9 = 40			
				C = Custom			

POEL SERIES MAXIMUM LIFE, MAXIMUM DIRT LOADING LIQUID FILTER BAGS



STANDARD FEATURES

- **No other bag holds more particulate**
- Manufactured in USA
- Adds an additional 890 cubic inches of depth filtration
- Standard size bags to fit most major housing brands
- Available in 1 to 200 micron ratings
- Dual Gradient Depth Media
- Designed for maximum dirt loading
- Choice of four different top rings
- Removes tramp oils from water with fine fiber dual gradient depth media
- Optional glazed media finish inhibits fiber migration
- Features heavy duty handle for easy removal, at no additional cost
- Reduces the number of change outs required, extending filter life
- Saves on labor costs by reducing change outs

SPECIFICATIONS

OPERATING PARAMETERS

MICRON RATINGS

1, 5, 10, 25, 50, 75, 100 and 200 microns

BAG SIZES

#1 - 7 1/16" diameter x 16 1/2" length

#2 - 7 1/16" diameter x 27" length

#12 - 8 1/8" diameter x 27" length

MATERIALS OF CONSTRUCTION

Bag: Polypropylene Felt

Ring: Polypropylene

Stainless Steel

Carbon Steel

Plastic Flanged

POEL TESTING

This image shows the dirt loading characteristics throughout the entire 2" thickness of the melt blown portion of the bag.



This image is a close up of the same media showing a complete loading of the filter cartridge



This image shows the outer part of the bag filter. It still has white areas. The outer bag is a support layer for the internal melt blown filter cartridge and is not expected to be full of contaminate, which happens with low efficiency filter bags



RESULTS

The bag was weighed after a complete drying period. The weight difference between the spent element and a new filter was 3713 grams (8.19 lbs). The element has captured a significant amount of particulate.

Our POEL bag will save you money by decreasing change-out times, which saves on shipping, housing maintenance and dirty bag disposal. All of these savings AND increasing efficiency offering you true filtration using your current housings.

BUILDING A PART NUMBER

Available Material	Micron Rating
POEL -Polypropylene Extended Life OREL - Oil Removal	1, 5, 10, 25, 50, 75, 100, 200
Finish or Cover	Bag Size
P = None (standard) FF = Fiber Free G = Glazed A = Automotive	#1 - 7 1/16" diameter x 16 1/2" length #2 - 7 1/16" diameter x 27" length #3 - 4 1/8" diameter x 8" length #4 - 4 1/8" diameter x 14" length #12 - 8 1/8" diameter x 27" length
Ring Style	Handle Options
S = Carbon Steel, standard 12" handle SS = Stainless Steel, standard 12" handle PO = Polypropylene, standard 12" handle F = Plastic Flange	No Symbol = Standard heavy-duty handle DH = Double Handle

MEDIA	MICRON RATING	FINISH OR COVER	BAG SIZE	RING STYLE	HANDLE OPTIONS
POEL	5	P	2	S	
POEL	1 50	P	1	S	DH
OREL	5 75	FF	2	SS	
	10 100	G	3	PO	
	25 200	A	4	F	
			12		

625 HF Series High Flow Cartridges

All elements are 5 layer construction for maximum pleat support and dirt loading.



- offers the highest grade, **90% and 99.98% efficient elements** on the market today
- Our media is **manufactured in-house** under strict guidelines to ensure consistency and maximum dirt loading
- **In-house lamination and calendaring** of our medias allow us to control the final media grades
- Complete in-house testing with a Capillary Flow Porometer guarantees a **superior and consistent product**
- With 8 micron ratings and multiple lengths and 4 end cap configuration to ensure we **produce the element you require**
- Elements have thermally bonded end caps and ultrasonic welded media seams for a **one piece construction**
- Final, one piece construction up to 40" long **ensures zero bypass**
- We install the maximum amount of media in each filter without pleat binding for **increased dirt loading capacity**
- Elements are **100% polypropylene**—media, inner and outer supports mesh and end caps
- Elements meet **FDA Title 21** regulations for food and water contact
- Cartridges are constructed in a **clean room environment**
- Cartridges may be ordered as final **rinsed with 18 mega ohm water**
- We offer **inside out OR outside in** flow pattern for your specific housing application.
- Longer service life equals reduced maintenance and downtime

Materials of Construction		Dimensions (nominal)	
Filter Media:	Polypropylene Melt Blown	Outside Diameter:	6.25"
Core:	Polypropylene	Lengths:	20", 30", 40", 60", & 80"
Netted Outer Cage:	Polypropylene		
Support Material:	Polypropylene		
Sealing:	Thermal Bond		
Gaskets/O-Rings:	Buna N, Viton®, Teflon®, Silicone, Neoprene & EDPM		
Performance Specifications			
Retention Ratings of 90% and 99.98% at: 1, 3, 5, 10, 25, 50 & 100 micron			
Operating Conditions		FDA Listed Materials	
Maximum Differential Pressure: 50 psid @ 180°F, 82°C		Manufactured from materials which are FDA listed for food contact applications in Title 21 of the U.S. code of federal regulations	
Toxicity		Purity	
Cartridges are manufactured with no additives or other manufacturing agents. We guarantee all materials used in the production meet FDA Title 21 of the Code of Federal Regulations 174.5 and 177.1520.		Cartridges are Free of Surfactants, Resins, Binders and Adhesives	
Sterilization			
Multiple Autoclaving for 30 Minutes at 250°F (121°C) under no End Load Conditions. In-line Steam Sterilization is not recommended. May be In-line Sanitized with Hot Water at 180°F (82°C) for 1 hour.			

Building a Part Number

625 HIGH FLOW
PLEATED
CARTRIDGE

	MEDIA	EFFICIENCY	MICRON	CARTRIDGE LENGTH	END CAP	GASKET / O-RING	18 MEGA OHM RINSE
625	E	A	1	5	3	B	R
625	E = Polypropylene	A = 90% B = 99.98%	.5 1 3 5 10 25 50 100	5 = 20 7 = 30 8 = 39 9 = 40 10 = 60 11 = 80 A = custom	4 = 222/Flat 5 = 226/Flat 6 = 225/Flat 9 = Flat/O ring A = Custom	B = Buna V = Viton® T = Teflon® S = Silicone N = Neoprene D = EPDM	R

LIQUID FILTER BAGS

Standard, Custom, Multi-Layered



FEATURES AND SPECIFICATIONS

- liquid filter bags are manufactured in the USA, and are made with the highest grade materials to offer you quality and efficiency in each bag
- All standard sizes are available with 12 different top rings to offer you the proper filter bag you need to adapt with your existing housings
- Ratings from 1 to 1000 micron and 8 different medias suitable to your application
- Bag Handles are standard on our bags at no additional cost
- Our filter bags are produced in a silicone free environment
- Custom bags, sleeves or panels can be produced to your specifications, offering you complete control of the filtration process
- Multi-Layered filter bags are available
- Optional Glazing inhibits fiber migration and enhances efficiency
- All materials used in production are FDA Title 21 compliant

Available Material	Micron Rating
PE -Polyester Felt	1, 5, 10, 25, 50, 75, 100, 200
PO -Polypropylene Felt	1, 5, 10, 25, 50, 75, 100, 200
PEM – Polyester Multifilament Mesh	100, 150, 200, 250, 400, 600, 800, 1000
NM – Nylon Multifilament Mesh	150
NMO – Nylon Monofilament Mesh	5, 10, 25, 50, 75, 100, 150, 200, 250, 300, 400, 600, 800, 1000
OR – Oil Removal	25

Finish or Cover	Bag Size
P = None (standard) FF = Fiber Free G = Glazed NMO = Nylon Monofilament Mesh Cover NM = Nylon Multifilament Mesh Cover C = Cerex (Spunbonded Nylon) Cover L = Spunbonded Polypropylene Cover R = Reemay (Spunbonded Polyester) Cover PEM = Polyester Multifilament Mesh Cover A = Automotive	1 = 7-1/16" dia x 16-1/2" L 2 = 7-1/16" dia x 32" L 3 = 4-1/8" dia x 8" L 4 = 4-1/8" dia x 14" L 5 = 4-1/8" dia x 24-1/2" L 7 = 5-5/8" dia x 15" L 8 = 5-5/8" dia x 21" L 9 = 5-5/8" dia x 32" L 12 = 8" dia x 32" L CN1 = Cuno [®] #1 size housing, 9" dia x 20" L CN2 = Cuno [®] #2 size housing, 9" dia x 30" L RP1 = Ronningen-Petter [®] #1 size housing, 8" dia x 30" L RP2 = Ronningen-Petter [®] #2 size housing, 8" dia x 40" L CM1 = Commercial Filters [®] #1 size housing, 7-5/16" dia x 16-1/2" L CM2 = Commercial Filters [®] #2 size housing, 7-5/16" dia x 31" L
Ring Style	Handle Options
S = Carbon Steel, standard 12" handle SS = Stainless Steel, standard 12" handle PO = Polypropylene, standard 12" handle DS = Drawstring F = FSI Plastic Flange NR = No Ring	No symbol = standard 12" polypropylene material NH = No Handle DH = Double Handle LH = 18" Handle RC = Reverse Collar

BUILDING A PART NUMBER

MEDIA	MICRON RATING	FINISH OR COVER	BAG SIZE	RING STYLE	HANDLE OPTIONS
PE	5	P	2	S	
PE PO PEM NM NMO OR	Refer to Chart above for Available Choices	P FF G NMO NM C L R PEM A	1 to CM2	S SS PO DS F NR	NH DH LH RC

Liquid Filters Industrial Manufacturing / Micro Electronics / Solvents

Industrial Environments required specialized filtration that will withstand heavy application use. CLS has the product line to filter from .02 - 1000 microns. Housings and filter cartridges are suited to your environment. Whether you are filtering natural gas to remove impurities or eliminating metal shaving in a metal fabrication shop.

RELATED PRODUCTS



Liquid Filter Bags



Stainless Steel Cartridges



Standard Efficiency Pleated Cartridges



Melt Blown Cartridges



String Wound Cartridges



High Efficiency Pleated Cartridge



Nylon 6,6 Membrane Cartridges



Polyethersulfone Membrane Cartridges



PTFE Membrane Cartridges



Carbon Cartridges



Universal Sorbent Media



Hazmat Sorbent Media



Oil-only Sorbent Media



POEL Extended Life Bag



625 HF Series High Flow Cartridges

Liquid Filters | **Oil and Gas / Power Generation (liquid)**

MicroGlass - Cellulose Blend or Resin Impregnated Cellulose Filter cartridges



Elements offer economical, high quality Beta rated filtration for applications where “absolute” filters are required. Elements are available in cellulose, glass-cellulose and microglass media with a variety of end configurations and sizes. The pleated design ensures high contaminant retention due to the large surface area. Elements are available in ratings from 2 to 30 microns.

The N Series elements is an economical solution when absolute rated filtration is not required and are constructed with the same high quality material used in the B series. Elements are used for the removal of contaminant from a wide range of products as either prefilters or final filters. These cartridges are manufactured in a wide variety of configurations for replacing current industry cartridges. This pleated element is a superior alternative to conventional string wound, resin bonded and meltblown cartridges. These elements are available in 10, 20, 30, 36 and 40” lengths.

Liquid Filters | **Synthetic Media Cartridges**



Designed for filtration of water, water based fluids, and a wide range of chemicals. These filter cartridges stand up to continuous use in water based fluids without the softening and/or deterioration common with many resin impregnated paper cartridges. These elements are made with an advanced synthetic polyester media, which allows high flow rates with low pressure drops as well as excellent temperature resistance.

SL elements are available in removal ratings from 5 to 40 microns. SLH elements have wire mesh support for pleat strength are available in micron ranges of 1/2 to 40. Sizes are available to replace many existing paper cartridges.

Liquid Filters | **Hydraulic and Lubrication Oil filters**

- [Engines](#)
- [Machinery](#)
- [Marine](#)

Hydraulic filter element applications are demanding and require filtration products that can withstand difficult conditions in industrial and mobile applications. Harsh conditions can often apply to hydraulic filter applications (like mining or military applications). Hydraulic power systems require assorted components like pumps, valves and cylinders to name a few. Keeping your system contamination-free with a quality hydraulic filter element can prolong the life of system components.

Stainless steel filter element products and metal felt filter element products for fluid power use. Either style can be cleaned to lengthen filter element life and reduce disposal costs.

Free and dissolved water in hydraulic systems can be removed using [Sorbent Water Removal Filter Elements](#). These products are pleated with a special water absorber layer.

Our hydraulic filter elements are ideal replacements for many OEM elements and are designed to be functionally and dimensionally interchangeable.



Liquid Filters Oil & Fuel Coalescers

Coalescer cartridges are offered in a variety of cartridge configurations to replace current industry cartridges. They are available with double open ends and flat gaskets, open ends with O-Ring seals, and thread base construction. Cartridges are available in a number of different diameters and lengths. All coalescers are single piece construction, resulting in increased strength and reducing the chance of bypass. We use a combination of one or more layers of pleated media and various layers of fiberglass. The pleated media removes the bulk of solids. Coalescing performance is determined by the type and number of layers of fiberglass.

Available in four different series of efficiency. These ratings are nominal and should be used for reference only:

Series	Rated at	Normally used for	Removes water down to
25 series	25 micron	fuels such as diesel or heating oils.	25 ppm
5 series	5 micron	place of the 25 series when more efficiency is or tighter filtration is desired.	10 ppm
2 series	2 micron	lighter hydrocarbons such as kerosene, gasoline, or naphtha.	less than 5 ppm
1 series	1/2 to 1 micron	is designed for maximum coalescing and particulate removal efficiency	less than 5 ppm

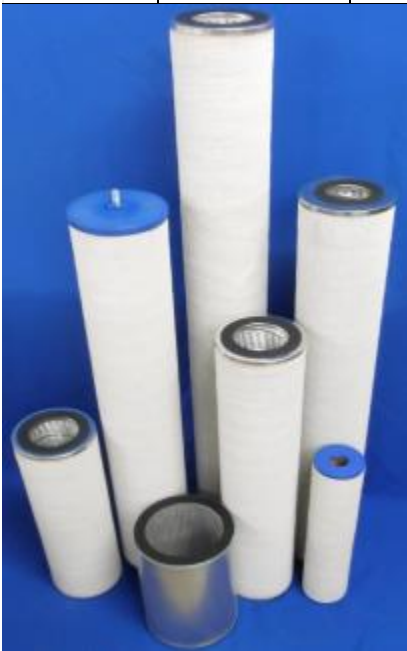

Liquid Filters Separators

Separator cartridge are available in two different designs – silicon treated pleated cellulose and a PTFE coated stainless steel screen. The silicon treated resin impregnated cellulose media is designed to repel small coalesced water droplets that do not settle by gravity and pass through the separator. This pleated media provides effective 5 micron particulate filtration. The PTFE coated screen separators are manufactured with 200 mesh stainless steel coated on both sides with PTFE. This media is hydrophobic allowing the hydrocarbon fluid to pass through while repelling the water droplets.

Center cores are perforated, plated steel. End caps are tin plated steel or glass reinforced nylon. Standard gaskets are Buna-N. Other gasket material are available upon request.



Liquid Filters|Process

CLS cartridges and media are specifically designed for manufacturing and separation of paints and inks in your environment. We know the removal of impurities from your products is essential to your success. This is why we work closely with you to ensure your filtration needs are met. CLS's filters have been designed to prevent unwanted large particulate formation in your products. CLS understands your need to provide consistency within your product line. Clean Liquid Systems can provide you the filtration products and support to ensure your operation flows smoothly.



Melt Blown Cartridges



String Wound Cartridges



Standard Efficiency Pleated Cartridges



Liquid Filter Bags



Bag Filter Housings



Cartridge Filter Housings



POEL Extended Life Bag



625 HF Series High Flow Cartridges

Liquid Filters | **Housings and Strainers**

Sanitary (Food, Beverage and Laboratory)



Single and multi-round housings are constructed of 316L stainless steel designed with standards for filtration applications requiring high purity production. Design characteristics minimize hold up volumes, provide for easy draining and cleanability. External surfaces mechanically polished and internal surface is acid washed for a consistent, easy care finish. Available to accommodate multiple configurations and up to 36 individual cartridges.

Additional styles of Multi-round housings are constructed of durable stainless steel and meet general purpose industrial and commercial filtration needs. All wetted welded surfaces are 316 stainless steel.

Accepts 10", 20", 30" and 40" cartridges with DOE, 222 and 226 configuration options.

High Flow Series Accepts large filter elements. Available in vertical or horizontal orientations, the High Flow housings can accept from 1 to 7 filter elements.

SCC/SCB SERIES

Single & Multi Round Sanitary Cartridge Housings

SCC/SCB Series housings robust design and high purity construction assures dependable protection for critical process applications

PROCESS FLUIDS

- Water (Ultrapure/R.O./D.I)
- Chemicals
- Food & Beverage
- Cosmetics
- Beer/Wine/Liquors
- Electronics
- Pharmaceuticals
- Vent



DESIGN SPECIFICATIONS

- Wetted components are 316LSS with 32Ra external polish and 25Ra internal polish (25Ra external available) All housings are passivated.
- SCC housings utilize a heavy duty stainless tri-clamp closure for ease of element changes
- SCB housings feature swing bolt closures to ensure positive sealing
- 150psi working pressure @ 300F
- 1-1/2" Tri-Clamp Vent/Gauge connection standard
- 1/2" Tri-Clamp Drain connections standard
- 222 or 226 style elements
- Removable Bottom Plate on multi-round housings allows for 100% access for cleaning
- Standard Silicone o-ring seals

OPTIONS

- Bevel Seat, I-Line, SMS, Flanged fittings
- Seal materials (EPDM, Viton, Teflon Encapsulated Silicone & Teflon Encapsulated Viton)
- Custom OEM designs

BUILDING A PART NUMBER: (SCB-5-30-226-2-TC-S = 5, 30" 226 ELEMENTS, 2" TRI-CLAMP, SILICONE)

Series	Element Qty.	Element Length	Element Type	Connection Size	Connection Type	Seal Material
SCC	1	10"	222	1"	TC=Triclamp	S=Silicone (std.)
		20"	226	1-1/2"		V=Viton
		30"				E=EPDM
		40"				TS/TV= Encapsulated Teflon
SCB	3	10"	222	2"	TC=Triclamp	S=Silicone (std.)
	5	20"	226	3"		V=Viton
	7	30"		4"		E=EPDM
	12	40"				TS/TV=
	21					Encapsulated Teflon

Liquid Filters | Industrial (Cartridge, Bag and Strainer Basket)

Filter housings come in many sizes and styles, and all serve as a bag filter housing, filter strainer, cartridge filter or basket strainer. The filter housing covers are easily removed without special tools, and the element is easily cleaned or replaced. Please contact us to learn more about our filter housing products.



Hydraulic Multiround Cartridge



Hydraulic Single Cartridge



Inline Strainers



Multiround Bag Housing



Multiround Duplex Bag



Multiround Swing Bolt Cartridge



Single Bag Series



Snap Band Cartridge



Snap Band Single Bag



Swing Bolt Cartridge



Swing Bolt Single Bag



Swing Bolt Single Duplex Bag

ICB SERIES

Multi-Round Industrial Cartridge Housings, Bolted Cover

ICB Series housings robust design and high quality construction assures dependable protection for industrial and commercial applications.

PROCESS FLUIDS

- Water
(Fresh/Sea/R.O./D.I./Waste)
- Chemicals
- Food & Beverage
- Soaps & Detergents
- Oils
- Coolants
- Paints & Coatings
- Pulp & Paper



DESIGN SPECIFICATIONS

- Carbon Steel, 304SS or 316SS
- Heavy Duty Eye Bolt closure for positive sealing and safety
- Accepts 10" thru 40" length elements (2.75" o.d. max)
- Sizes to accommodate 3 thru 225 elements
- Universal cups and compression top plate accepts DOE, 222-Flat or 222-Fin style cartridges
- Bearing Assist Davit Lift Cover on all housings over 22 elements
- Differential/Drain/Vent connections standard
- 150psi design pressure / 300F max temp
- Standard Buna-N o-ring seal
- Finish: Passivated with Bead Blast Finish

OPTIONS

- NPT/Flanges/Tri-Clamp
- Seal materials (EPDM, Viton, Teflon Encapsulated Silicone & Teflon Encapsulated Viton)
- Sanitary Polish
- Hydraulic Assist Lift
- Custom OEM designs

BUILDING A PART NUMBER:

(ICC-5-30-D-2-N-6-E = 5, 30" DOE/222 ELEMENTS, 2" NPT, 316SS, EPDM)

Series	*Qty.	Element Length	Element Style	Connection Size	Connection Type	Outlet Location	Material	Seal
ICB	3	10"	D=DOE/222	1-1/2"	N=NPT	A=Side	C=Carbon Steel	B=Buna(std)
	5	20"	6=226	2"	F=Flange	B=Bottom	4=304SS	E=EPDM
	7	30"		3"	T=Tri-Clamp	C=Custom	6=316SS	V=Viton
	12	40"		4"				TV=Encaps
	22			6"				TS=Encaps
	36							
	52							

ICS SERIES

Single Cartridge Housings, Clamped Cover

ICS Series housings robust design and high quality construction assures dependable protection for industrial and commercial applications.

PROCESS FLUIDS

- Water
(Fresh/Sea/R.O./D.I./Waste)
- Chemicals
- Food & Beverage
- Soaps & Detergents
- Oils
- Coolants
- Paints & Coatings
- Pulp & Paper



DESIGN SPECIFICATIONS

- 304SS, 316SS or 316LSS
- Heavy Duty Clamp closure for tool free element changes
- 150 psi max. working pressure
- -Drain/Vent Connections
- Standard design accepts DOE and 222 style cartridges (2.75" O.D. max)
- 316SS ergonomic threaded nut accommodates different length elements (9.75" vs. 10", etc.)
- Stainless Mounting Bracket standard
- EPDM o-ring seal
- Finish: Acid Wash & Electropolish standard

OPTIONS

- ANSI 150# Flanges / Sanitary Connections
- 226 Style Element
- Seal materials (Viton, Encaps. Teflon, Silicone)
- Sanitary Polish
- Custom OEM designs

HOUSING DATA

Model	Cartridge Size	Max. Flow (gpm)*
ICS-10	9.75"-10"	7
ICS-20	19.5"-20"	14
ICS-30	30"	21

*Maximum flow rates based on 1cps and 25 micron wound element. Viscosity, micron rating, element type and connection size will determine actual flow rates.

BUILDING A PART NUMBER: (ICS-20-D-1-N-6-E = 20" DOE/222 ELEMENT, 1" NPT, 316SS, EPDM)

Series	Cartridge Length	Connection Type	Connection Size	Connection Type	Material	Gasket
ICS	10	D=DOE/222	3/4"	N=NPT	4=304SS	E=EPDM
	20	6=226	1"	F=Flange	6=316SS	S=Silicone
	30			T=Tri-Clamp	6L=316LSS	V=Viton
						T=Teflon

ICC SERIES

Multi-Round Industrial Cartridge Housings, Clamped Cover

ICC Series housings robust design and high quality construction assures dependable protection for industrial and commercial applications.

PROCESS FLUIDS

- Water
(Fresh/Sea/R.O./D.I/Waste)
- Chemicals
- Food & Beverage
- Soaps & Detergents
- Oils
- Coolants
- Paints & Coatings
- Pulp & Paper



DESIGN SPECIFICATIONS

- 304SS, 316SS or 316LSS
- Heavy Duty Stainless Clamp Closure with ergonomic grip allows for tool free cartridge changes
- 150psi design pressure / 300F max temp
- Accepts 10" thru 40" length elements (2.75" o.d. max) Universal cups and compression top plate accepts DOE, 222-Flat or 222-Fin style cartridges
- Differential/Drain/Vent connections standard
- Stainless legs
- Standard EPDM o-ring seal
- Finish: Acid Wash with Electropolish exterior

OPTIONS

- Flanges/Tri-Clamp
- Seal materials (Viton, Teflon Encapsulated Silicone & Teflon Encapsulated Viton)
- Sanitary Polish
- Custom OEM designs

BUILDING A PART NUMBER:

(ICC-5-30-D-2-N-6-E = 5, 30" DOE/222 ELEMENTS, 2" NPT, 316SS, EPDM)

Series	Element Qty.	Element Length	Element Style	Element Size	Connection Type	Material	Seal Material
ICC	3	10"	D=DOE/222	1-1/2"	N=NPT	4=304SS	E=EPDM
	4	20"	6=226	2"	F=Flange	6=316SS	V=Viton
	5	30"			T=Tri-Clamp	6L=316LSS	TS=Teflon/Silicone
	7	40"					TV=Teflon/Viton

IHF SERIES

Industrial High Flow Cartridge Housings

IHF Series housings robust design and high quality construction assures dependable protection for industrial and commercial applications.

PROCESS FLUIDS

- Water
(Fresh/Sea/R.O./D.I./Waste)
- Desalination
- Power Generation
- Chemicals
- Oils
- Coolants
- Food & Beverage
- Pulp & Paper



OPTIONS

- Tri-Clamp/DIN Flanges/Victaulic connections
- Seal materials (Viton, Buna, Encapsulated Teflon)
- Duplexing
- Custom OEM designs



DESIGN SPECIFICATIONS

- Carbon Steel, 304SS, 316SS or 316LSS
- Swing Lid design with Eyebolt closure for dependable sealing / Davit Arm standard on larger sizes
- 150psi design pressure / 300F max temp
- Sizes to accommodate 1-19 elements (larger available)
- Accepts 40" or 60" length elements
- Designs to accept any mfg. elements, consult LFH prior to ordering
- Inside-Out or Outside-In flow path designs available
- Differential/Drain/Vent connections standard
- Standard EPDM o-ring seal
- Finish: 2-Part Epoxy on Carbon Steel, Acid Wash with Electropolish exterior on Stainless

BUILDING A PART NUMBER:

(IHF-5-6-H-6F-4-E=(5) 60" ELEMENTS, HORIZONTAL, 6" FLANGES, 304SS, EPDM)

Series	Element Qty.	Element Length	Mounting Style	Connection Type	Material	Seal Material	Element
IHF	1-19	4=40"	H=Horizontal	2"-12"	C=Carbon	E=EPDM (std.)	Specify Mfg. & Model
		6=60"	V=Vertical	F=Flange	4=304SS	V=Viton	
					6=316SS	B=Buna	
					6L=316LSS	TV=Teflon/Viton	

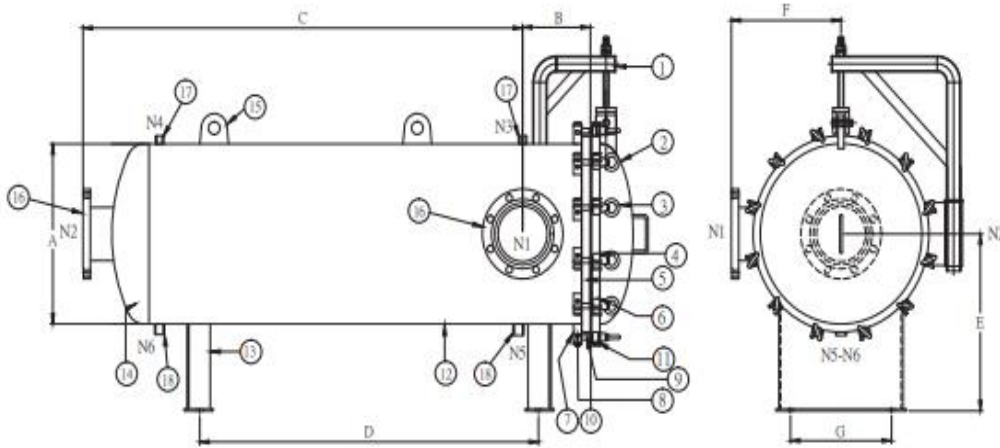

NO.	DESCRIPTION	NO.	DESCRIPTION
1.	Screw	10.	O-ring
2.	Top cover	11.	Eye nut Socket
3.	Eye nut	12.	Shell
4.	Top cover flange	13.	Support Leg
5.	Shell flange	14.	Bottom cover
6.	Washer	15.	Lug
7.	Eye bolt Socket	16.	Port(Inlet/Outlet)
8.	Spindle	17.	Vent
9.	Eye bolt	18.	Drain

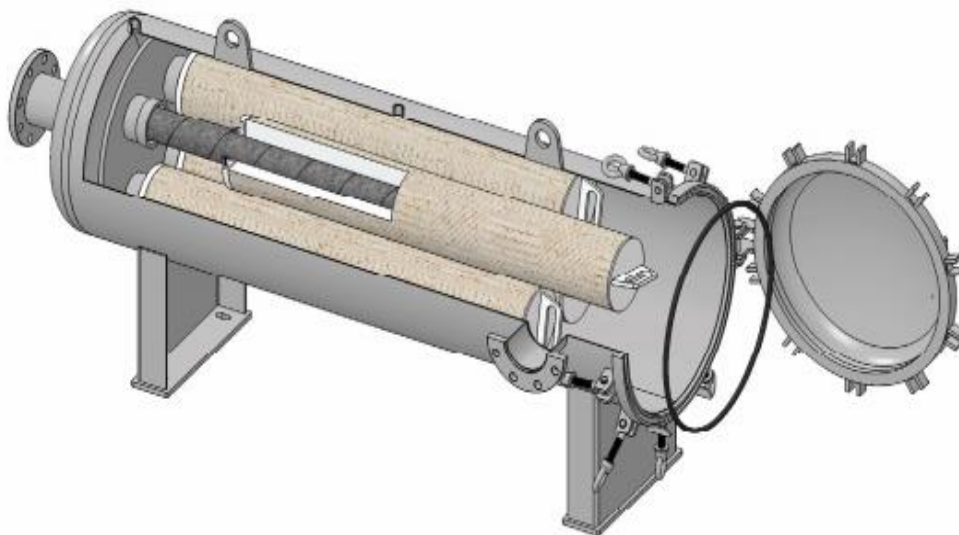

MBB SERIES

Multi-Bag Housings, Bolted Cover, 2-23 Bag Capacity

MBB Series housings robust design and high quality construction assures dependable protection for industrial and commercial applications.

PROCESS FLUIDS

- Water
(Fresh/Sea/R.O./D.I./Waste)
- Chemicals
- Food & Beverage
- Soaps & Detergents
- Oils
- Coolants
- Paints & Coatings
- Pulp & Paper



Bolted Housing With Davit

DESIGN SPECIFICATIONS

- Carbon Steel, 304SS or 316SS
- Eye-Nut/Swing Bolt Closure for high pressure safety
- Davit Lift Cover w/ Bearing assist for ease of operation
- 150psi max. working pressure / Hydro-tested @ 225psi
- Industry Size #2 316SS Restrainer Baskets w/ 9/64" perforations
- Differential/Drain/Vent Connections
- Stainless 3-Point bag locks for positive sealing
- Recessed lip prevents spills during bag changes
- Standard Buna-N Seals
- Finish: 2-Part Epoxy on Carbon Steel / Passivation & Glass Bead on 304SS & 316SS
- ANSI 150# R.F. Flanged Connections (others available on request)

OPTIONS

- Low Profile Side In, Side Out / Bottom In, Bottom Out / Custom
- Seal materials (Viton, EPDM, Silicone)
- Electropolish Finish
- ASME Code Stamp
- Mesh Lined Basket
- Custom OEM designs

HOUSING DATA

Basket Qty.	Surface Area (f2)	Std. Connection	Max. Flow (gpm)*
2	8.8	3"	400
3	13.2	4"	600
4	17.6	4"	800
5	22.0	6"	1000
6	26.4	6"	1200
7	30.8	8"	1400
8	35.2	8"	1600
10	44.0	8"	2000
12	52.8	10"	2400
17	74.8	10"	3400
23	101.2	12"	4600

*Maximum flow rates through housings determined with water and no filter bag installed. Viscosity, filter bag and connection size will affect flow rates. Please refer to sizing charts

(MODEL MBB) CONNECTION SIZE VS. PRESSURE DROP

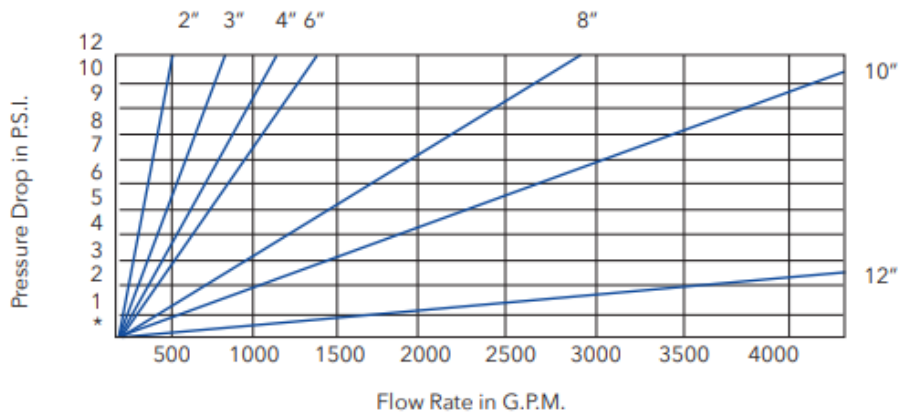

BUILDING A PART NUMBER: MBB-6-6-F-A-4-15=6 BAG, 6" FLANGES, SIDE IN/OUT, 304SS)

Basket Qty.	Connection Size	Connection Type	Connection Location	Material	Pressure Rating
2	3"	F = Flange	A=Side In/Side Out	C=Carbon Steel	15=150psi
3	4"		B=Bottom In/ Bottom Out	4=304SS	
4	6"		C=Custom	6=316SS	
5	8"				
6	10"				
7	12"				
8					
10					
12					
17					

MBC SERIES

Multi-Bag Housings, Clamped Cover, 2-12 Bag Capacity

MBC Series housings robust design and high quality construction assures dependable protection for industrial and commercial applications.

PROCESS FLUIDS

- Water
(Fresh/Sea/R.O./D.I./Waste)
- Chemicals
- Food & Beverage
- Soaps & Detergents
- Oils
- Coolants
- Paints & Coatings
- Pulp & Paper



DESIGN SPECIFICATIONS

- Carbon Steel, 304SS or 316SS
- RAPID-LOK Quick clamp opening mechanism for fast bag changes
- Counter balanced spring assist lift for ease of operation
- 150psi max. working pressure / Hydro-tested @ 225psi
- Industry Size #2 316SS Restrainer Baskets w/ 9/64" perforations
- Differential/Drain/Vent Connections
- Stainless 3-Point bag locks for positive sealing
- Recessed lip prevents spills during bag changes
- Standard Buna-N Seals
- Finish: 2-Part Epoxy on Carbon Steel / Passivation & Glass Bead on 304SS & 316SS
- ANSI 150# R.F. Flanged Connections (others available on request)

OPTIONS

- Low Profile Side In, Side Out / Bottom In, Bottom Out / Custom
- Seal materials (Viton, EPDM, Silicone)
- Electropolish Finish
- ASME Code Stamp
- Mesh Lined Basket
- Custom OEM designs

HOUSING DATA

Basket Qty.	Surface Area (f2)	Std. Connection	Max. Flow (gpm)*
2	8.8	3"	400
3	13.2	4"	600
4	17.6	4"	800
5	22.0	6"	1000
6	26.4	6"	1200
7	30.8	8"	1400
8	35.2	8"	1600
10	44.0	8"	2000
12	52.8	10"	2400

*Maximum flow rates through housings determined with water and no filter bag installed. Viscosity, filter bag and connection size will affect flow rates. Please refer to sizing charts

(MODEL MBC) CONNECTION SIZE VS. PRESSURE DROP

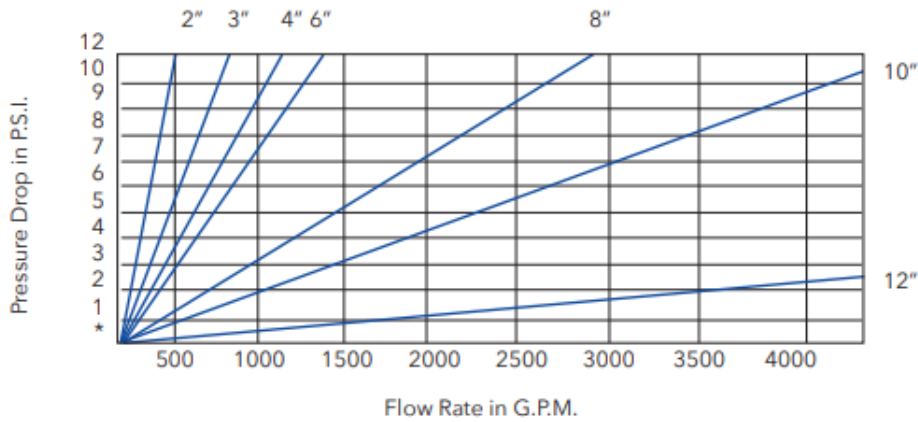

BUILDING A PART NUMBER: (MBC-6-6-F-A-4-15=6 BAG, 6" FLANGES, SIDE IN/OUT, 304SS)

Basket Qty.	Connection Size	Connection Type	Connection Location	Material	Pressure Rating
2	3"	F = Flange	A=Side In/Side Out	C=Carbon Steel	15=150psi
3	4"		B=Bottom In/ Bottom Out	4=304SS	
4	6"		C=Custom	6=316SS	
5	8"				
6	10"				
7					
8					
10					
12					

SBB SERIES

Single Bag Housings, Bolted Cover, #1, #2, #3, #4 & #12 Industry Sizes

SBB Series housings robust design and high quality construction assures dependable protection for industrial and commercial applications.

PROCESS FLUIDS

- Water (Fresh/Sea/R.O./D.I./Waste)
- Oils
- Chemicals
- Coolants
- Food & Beverage
- Paints & Coatings
- Soaps & Detergents
- Pulp & Paper



DESIGN SPECIFICATIONS

- Carbon Steel, 304SS or 316SS
- Eye-Nut/Swing Bolt Closure (4-Bolt #1, #2 & #12 / 3-Bolt #3 & #4) for high pressure operation safety
- 150psi max. working pressure / Hydro-tested @ 225psi
- 316SS Restrainer Basket w/ 9/64" perforations
- Differential/Drain/Vent Connections
- 316SS Spring style bag compressor for positive sealing
- Concave evacuation style cover prevents spills during bag changes
- Stainless adjustable legs
- Standard Buna-N Seals
- Finish: 2-Part Epoxy on Carbon Steel / Passivation & Glass Bead on 304SS & 316SS

OPTIONS

- NPT / ANSI 150# Flanges / Sanitary Connections
- Side In, Side Out / Side in, Bottom Out / Custom
- Seal materials (Viton, EPDM, Encaps. Teflon, Silicone)
- Electropolish Finish
- ASME Code Stamp
- Mesh Lined Basket
- Custom OEM designs

HOUSING DATA

Size	Basket Dims (in)	Surface Area (f2)	Max. Flow (gpm)*
#1	6.7 x 15	2.3	100
#2	6.7 x 30	4.4	200
#3	3.9 x 6	0.5	25
#4	3.9 x 12	1.0	50
#12	8 x 30	5.5	200

*Maximum flow rates through housings determined with water and no filter bag installed. Viscosity, filter bag and connection size will affect flow rates. Please refer to sizing charts

(MODEL SBB) CONNECTION SIZE VS. PRESSURE DROP

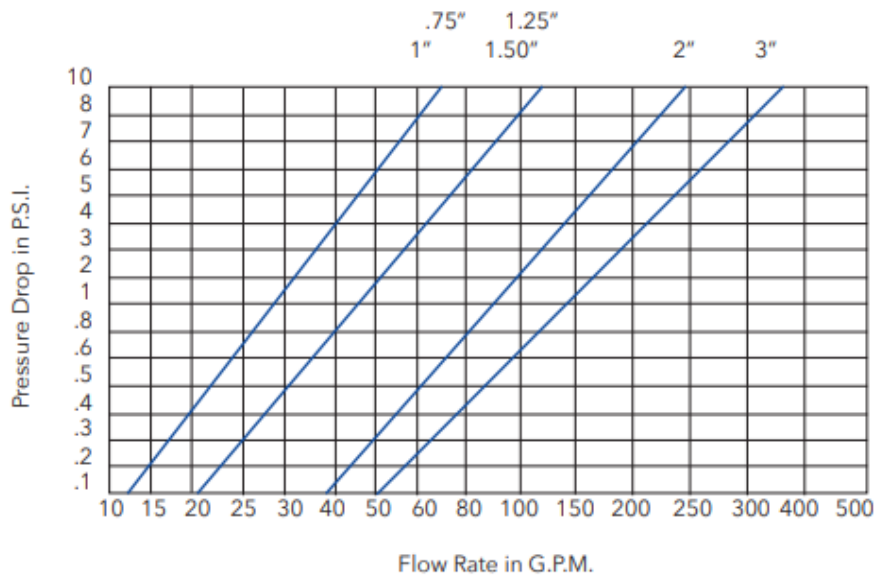

BUILDING A PART NUMBER: (SBB-2-2-N-A-4-15 = #2, 2"NPT, SIDE OUT, 304SS)

Series	Basket Size	Connection Size	Connection Type	Outlet Location	Material	Pressure Rating
SBB	#1	1-1/2"	N=NPT	A=Side	C=Carbon Steel	
	#2	2"	F=Flange	B=Bottom	4=304SS	15=150psi
	#12	3"	T=Tri-Clamp	C=Custom	6=316SS	
SBB	#3	1"	N=NPT	A=Side	C=Carbon Steel	
	#4	1-1/2"	F=Flange	B=Bottom	4=304SS	15=150psi
			T=Tri-Clamp	C=Custom	6=316SS	

SBC SERIES

Single Bag Housings, Clamped Cover, #1, #2, #3, #4 & #12 Industry Sizes

SBC Series housings robust design and high quality construction assures dependable protection for industrial and commercial applications.

PROCESS FLUIDS

- Water
(Fresh/Sea/R.O./D.I./Waste)
- Chemicals
- Food & Beverage
- Soaps & Detergents
- Oils
- Coolants
- Paints & Coatings
- Pulp & Paper



DESIGN SPECIFICATIONS

- 304SS, 316SS or 316LSS
- Heavy Duty Stainless Clamp Closure with ergonomic grip allows for tool free bag changes
- 150psi design pressure / 100psi operating pressure
- 316SS Restrainer Basket w/ 9/64" perforations
- Differential/Vent Connections
- Stainless adjustable legs
- Standard EPDM o-ring seal
- Finish: Acid Wash with Electropolish exterior

OPTIONS

- NPT / ANSI 150# Flanges / Sanitary Connections
- Side In, Side Out / Side in, Bottom Out / Custom
- Seal materials (Viton, Buna, Encaps. Teflon, Silicone)
- Mesh Lined Basket
- Custom OEM designs

HOUSING DATA

Size	Basket Dims (in)	Surface Area (f2)	Max. Flow (gpm)*
#1	6.7 x 15	2.3	100
#2	6.7 x 30	4.4	200
#3	3.9 x 6	0.5	25
#4	3.9 x 12	1.0	50
#12	8 x 30	5.5	200

*Maximum flow rates through housings determined with water and no filter bag installed. Viscosity, filter bag and connection size will affect flow rates.

(MODEL SBC) CONNECTION SIZE VS. PRESSURE DROP

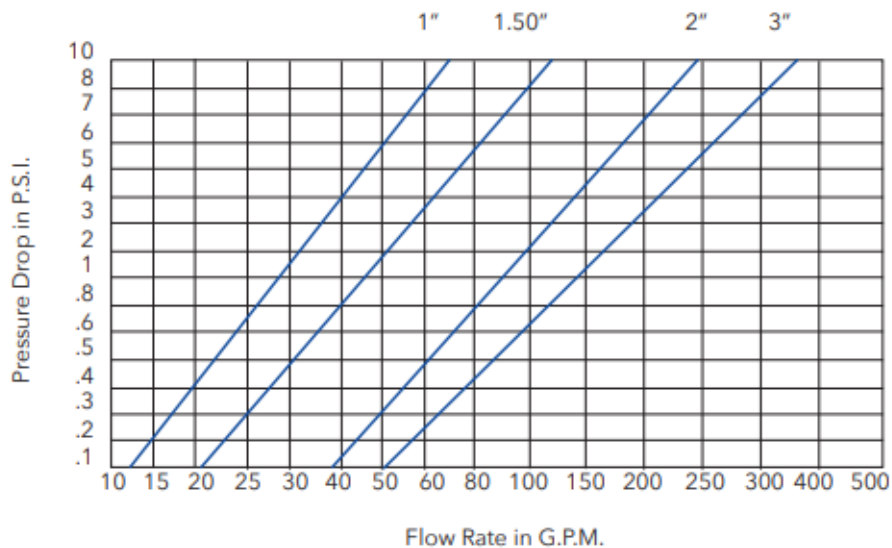

BUILDING A PART NUMBER: (SBC-2-2-N-A-6-15 = #2, 2" NPT, SIDE OUT, 316SS)

Series	Basket Size	Connection Size	Connection Type	Outlet Location	Material	Pressure Rating
SBC	#1	1-1/2"	N=NPT	A=Side	4=304SS	
	#2	2"	F=Flange	B=Bottom	6=316SS	15=150psi
	#12	3"	T=Tri-Clamp	C=Custom	6L=316LSS	
SBC	#3	1"	N=NPT	A=Side	4=304SS	
	#4	1-1/2"	F=Flange	B=Bottom	6=316SS	15=150psi
			T=Tri-Clamp	C=Custom	6L=316LSS	

SBT SERIES

Single Bag Housings, Top Flow Bolted Cover, #1 & #2 Industry Sizes

SBT Series housings robust design and high quality construction assures dependable protection for industrial and commercial applications.

PROCESS FLUIDS

- Water
(Fresh/Sea/R.O./D.I./Waste)
- Chemicals
- Food & Beverage
- Soaps & Detergents
- Oils
- Coolants
- Paints & Coatings
- Pulp & Paper



DESIGN SPECIFICATIONS

- Carbon Steel, 304SS or 316SS
- Eye-Nut/Swing Bolt Closure, 4-Bolt for high pressure operation safety
- 150psi max. working pressure / Hydro-tested @ 225psi
- 316SS Restrainer Basket w/ 9/64" perforations
- Differential/Drain/Vent Connections
- Top inlet with flow through cover improves flow distribution and pressure loss
- Machined cover seals directly on bag for bypass free filtration
- Reduced headroom for unfiltered liquid makes bag change outs quick & easy
- Stainless adjustable legs
- Standard Buna-N Seals
- Finish: 2-Part Epoxy on Carbon Steel / Passivation & Glass Bead on 314SS & 316SS

OPTIONS

- NPT / ANSI 150# Flanges / Sanitary Connections
- Side In, Side Out / Side in, Bottom Out / Custom
- Seal materials (Viton, EPDM, Encaps. Teflon, Silicone)
- Electropolish Finish
- ASME Code Stamp
- Mesh Lined Basket
- Custom OEM designs

HOUSING DATA

Size	Basket Dims (in)	Surface Area (f2)	Max. Flow (gpm)*
#1	6.7 x 15	2.3	100
#2	6.7 x 30	4.4	200

*Maximum flow rates through housings determined with water and no filter bag installed. Viscosity, filter bag and connection size will affect flow rates.

(MODEL SBT) CONNECTION SIZE VS. PRESSURE DROP

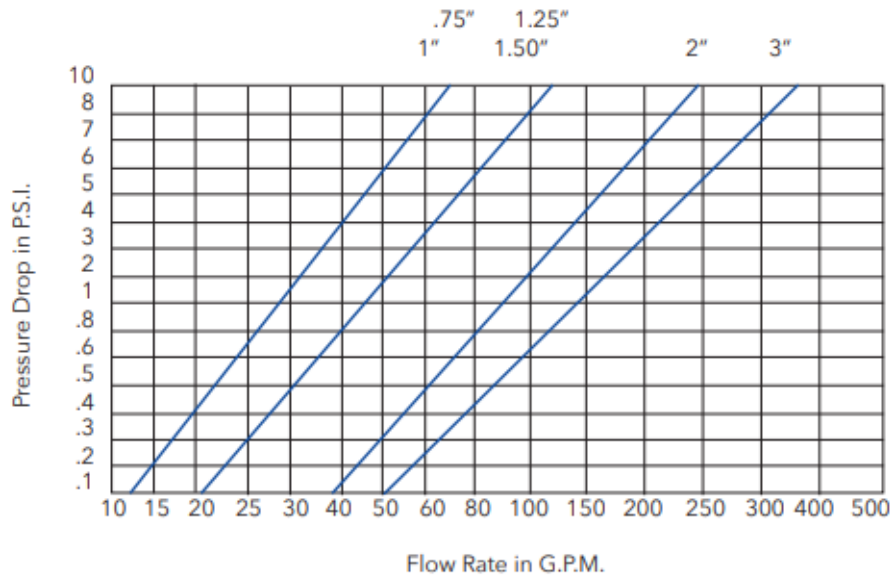

BUILDING A PART NUMBER: (SBT-1-2-N-A-6-15=#1, 2" NPT, SIDE OUT, 316SS)

Series	Basket Size	Connection Size	Connection Type	Outlet Location	Material	Pressure Rating
SBT	#1	1-1/2"	N=NPT	A=Side	C=Carbon Steel	
	#2	2"	F=Flange	B=Bottom	4=304SS	15=150psi
		3"	T=Tri-Clamp		6=316SS	

Shown Below are common Strainer baskets

Strainer baskets may be lined with finer mesh screen or used with a disposable bag. The bags are available in many grades of felt materials with numerous types of felt media. We can offer assistance to help determine what may be best for your application



Liquid & Vapor Phase Activated Carbon Media

(Deep Bed Scrubbers and Vessels) / Positive Pressurization Unit (PPU)

Bulk Activated carbon media (Available in bags, boxes, drums or super sacks)

- [Toxic Fumes /VOC Removal/H²S Removal](#)
- [Lift and pump stations / Holding tanks /Taste and Odor Control /Chloramine Removal](#)
- [Portable water treatment / Ground water remediation](#)
- [Soil Vapor Extraction /Industrial process treatment/ Spill cleanup](#)

Clean Liquid Systems offers the highest quality products for superior performance and efficiency for water treatment. We specialize in products that remove and reduce chemicals, pesticides, chloramines, unwanted contaminants, toxins, PFOA & PFOS contaminants, unwanted colors, odors, and tastes.

Industries Served: Aquarium, Car Washes, Drinking Water, Desalination, Highly Purified Water, Municipal Water, Process Water, POE/POU, Produced Water, Wastewater, Water Purification and Reuse



Air Filtration for Commercial & Industrial Applications

Our vapor phase carbon media is used as a typical treatment to remove contaminants and pollutants from the air by adsorption. Depending on your application, a coal or coconut shell base material paired with an impregnate of a specific type and concentration will be available. This activated carbon possesses a high mechanical strength and has a great distribution of macro and micro pores that accommodate a variety of molecular sizes and offers a low flow resistance.



Activated carbon media can be used for the remediation of vapors generated, the removal of VOCs from the air, soil venting and removal of other organics such as ammonia, sulfur compounds, mercury, and amines.

We will help you determine which media is right for your vapor treatment application, bulk orders available

Large Chem Scrub Units

Hold up to 20,000 pounds of activated carbon.

May be run in duplex style side by side OR run as daisy chain style to run multiple units at one time.



Applications:

These can be used for cleaning of fracking water or removal of H₂S from Liquid Natural gas. They can be piped as duplex vessels or in series for deep scrubbing of chemicals.

Designed to treat liquid in a variety of adsorption applications. Modular design enables them to fit in most installation areas. There are many options for our RL Series scrubbers, contact our sales team to assist you.

Kitchen Pollution Control Units

Pollution Control Units (PCU)

Control Rooms/ Restaurant Odor Control / Grow Rooms / Refineries / Casinos

Exhaust or Recirculation Units ensures your computer equipment operates within a corrosive free environment, and within the guidelines of major computer and instrument manufacturers' warranties. Equipment Advantages: 1. Self-Contained Exhaust or Recirculation System - Provides particulate and gaseous filtration, removing contaminants generated by in-room sources and those brought in from outside. 2. Target Specific Gases - Multiple banks of media allows system to be configured to handle the contaminant gases present in your environment. 3. System Design Flexibility - Design flexibility to meet your specific needs. 4. Local Service - Trained representatives are supported by laboratory services including environmental corrosion classification and media life analysis testing.

Two Pass Pollution Control Unit complete with fan shown below. This is available with or without fan and may be customized to be an exhaust only or inline unit.



Various media types available. Blended Carbon or Potassium Permanganate coated alumina beads.



-9

Pollution Control Units /Deep Bed Scrubbers

Sewage/ Waste water Treatment facilities

- Toxic Fumes /VOC Removal/H²S Removal
- Lift and pump stations / Holding tanks /Taste and Odor Control
- Industrial process treatment
- Spill cleanup

Deep Bed Scrubber shown below are typically used for positive pressure on control rooms. These units can have 6” to 18” thick beds and multiple series of stages of filter media. Often these units will have different media in the different sections to adsorb a range of gases. Deep Bed Scrubber (DBS) are designed for areas where there are high contaminant Gas levels and provide more effective protection against environmentally induced corrosions in control and switch gear rooms equipped with electronic process control systems, refineries, steel mills, smelters, chemical plants, petrochemical plants and other hostile environments.



Equipment Advantages:

1. Media Selection: Custom selection of up to 36 inches of different chemisorbant media, depending on the corrosive gases present in the environment.
2. Economical: Design allows for higher airflow rates and higher efficiencies at lower CFM costs.
3. System Compatibility: Designed to sit outside the space to be placed under positive or negative pressure . The Deep Bed Scrubber delivers clean pressurization air to recirculation systems, side access systems, or HVAC equipment.
4. Local Service: Our global Listwork of experienced representatives provide a comprehensive service program to support each system in the field.

Air | Vapor Phase Activated Carbon

Disposable Bonded Carbon Blocks in Panels, V-cells or Cylindrical

Carbon Block Technology in V-cell
Frame



Kitchen PCU systems Replacement Bonded Carbon Panels for Odor Control

Description:

Clean Liquid Systems LLC offers a complete line of replacement odor control filters for use in Captive Aire® Pollution control units. Our Green Matrix LP filters offer superior odor removal at an affordable price.

Applications:

LP filters are designed for direct installation into Captive Aire® pollution control units, no retrofitting of filter tracks needed. The LP series filters are available in both standard duty and heavy duty designs and available in both 16x20x4 and 20x25x4 sizes

Benefits and Features:

- Direct Fit
- Exceptional odor removal
- Multiple carbon and Impregnated media
- All Metal Construction
- Light Weight
- Dust free operation
- Low pressure drop

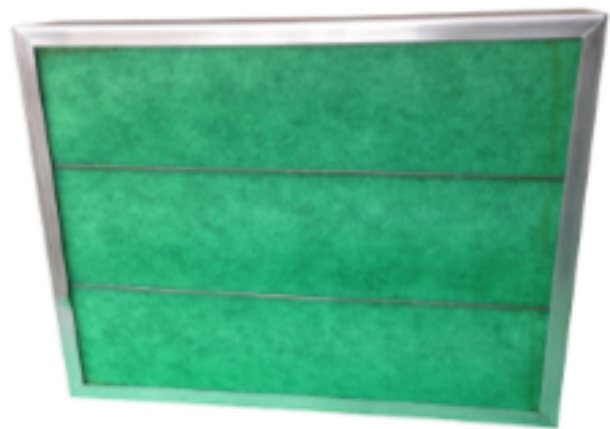

Standard Duty Direct Replacement for OE BPSL Odor Control Filters.		
Part Number	Description	Captive Part #
KBP 20000	16x20x4 Carbon	BPSL31230
KBP 20001	16x20x4 Kitchen Media	BPSL31227
KBP 20002	16x20x4 Blended Media	BPSL31224
KBP 20004	16x20x4 Caustic	BPSL31228
KBP 20010	20x25x4 Carbon	BPSL31231
KBP 20011	20x25x4 Kitchen Media	BPSL31226
KBP 20012	20x25x4 Blended Media	BPSL31222
KBP 20013	20x25x4 Caustic	BPSL31229

HEAVY DUTY Replacements for the OE B series Odor Control Filters		
Part Number	Description	Captive Part #
KBP 20200	16x20x4 Carbon	B21197
KBP 20201	16x20x4 Kitchen Media	B21198
KBP 20202	16x20x4 Blended Media	B21199
KBP 20203	16x20x4 Caustic	B21200
KBP 20210	20x25x4 Carbon	B21709
KBP 20211	20x25x4 Kitchen Media	B21710
KBP 20212	20x25x4 Blended Media	B21711
KBP 20213	20x25x4 Caustic	B21712

Pleated Activated Carbon V- cells | with MERV 13 or MERV 15 efficiencies (low pressure drop)

HEAVY DUTY Industrial grade VAPCarbon V™ model filters are made up of activated carbon media, close pleated and bonded in a rigid V shaped construction with. These filters operate with no carbon shedding, with very low pressure drop and are incinerable. A combination of synthetic media and activated carbon ensure higher degree of filtration efficiency. Filters are designed for odor removal in air conditioning and industrial process applications. A header frame design allows easy installation in holding frames and housings. These filters are ideal for application in commercial buildings, airports, hospitals, hotels, restaurants etc.



Features 100% synthetic filter media made with activated carbon closely pleated and arranged in a V configuration which accommodates a very large quantity of filter media. The Mini-Pleated media packs are arranged in a perfect V design and sealed to the enclosing frame made up of (ABS). Each filter has a very large media area providing low initial pressure drop. These models are high capacity to handle large airflows, easy to install and dispose, suitable for gas adsorption and chemisorption, particulate filtration along with odor removal etc. MERVCARB VM™ is made up of a dual layer media of carbon and synthetic to provide an efficiency of MERV13 and MERV 15 grade as per ASHRAE 52.2. All filters available in 20mm or 25mm header.

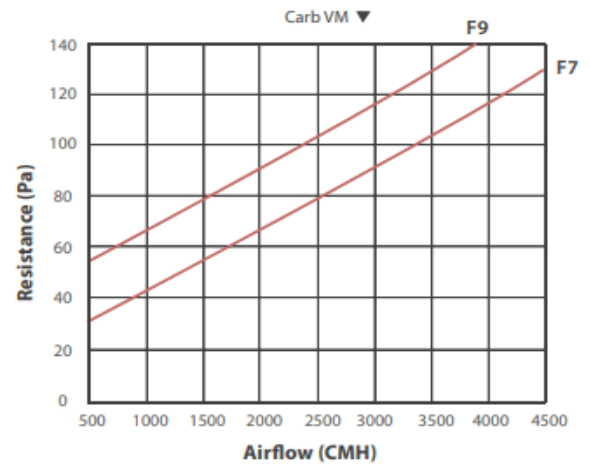
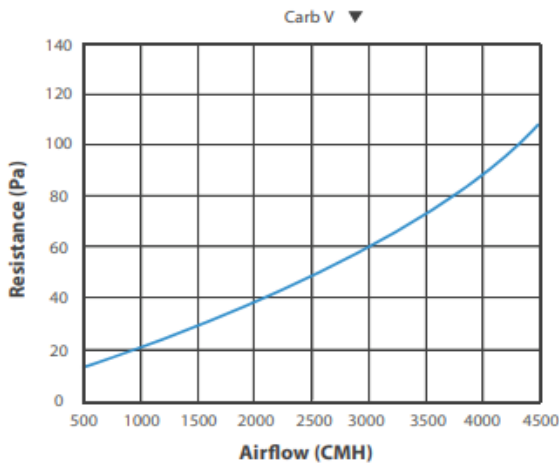

Selection Chart : Carb V ▼

Filter Sizes (Inches)	Filter Size (mm)	Rated Airflow (CMH)	Initial Resistance (Pa)	Final Resistance (Pa)	Media Area (M2)
24 x 24 x 12	Size: 592 x 592 x 292	3400	70	400	9
24 x 20 x 12	Size: 592 x 490 x 292	2400	70	400	6
24 x 12 x 12	Size: 592 x 292 x 292	1700	70	400	4.5

Selection Chart : Carb VM ▼

Filter Sizes (Inches)	Filter Size (mm)	Rated Airflow (CMH)	Initial Resistance (Pa) F7 / F9	Final Resistance (Pa)	Media Area (M2)
24 x 24 x 12	Size: 592 x 592 x 292	3400	100 / 125	400	9
24 x 20 x 12	Size: 592 x 490 x 292	2400	100 / 125	400	6
24 x 12 x 12	Size: 592 x 292 x 292	1700	100 / 125	400	4.5

● Humidity : 95% ● Temperature : 60 °C ● Please contact factory for special toxic or VOC gases

Disposable V-cells with honeycomb “Style VH” is a new generation carbon filter that meets the demand of odor removal in applications where the concentrations of odor are high. Carbon filters available these days are heavy and hence require more effort in handling. Carb VH is designed in a low weight construction and the weight of carbon dominates in its total weight. A variety of carbon or carbon blend selections are offered depending on the application.

Available in depth of 12”, 16” and 17” depth



Media Features and Technical Details

Activated Carbon Filter media used in these filters are basically activated carbon or alumina. They are arranged in a honeycomb of specific thickness and forms V cells for lower resistance in a rigid plastic casing. Frames are available in 12, 16 or 17” depth. Standard filter sizes are available 24 x 24, 12 x 24 and 20 x 24. These filters are not re-usable and should be disposed of after use as per local requirements.

Selection of filter media is based on the application. Customers should specify the VOC to be treated and filters can be then selected based on its residence time. Residence time is the term given to the time that a gas stream contacts a carbon bed.

Selection Chart : Carb VHC/VHA ▼

Filter Sizes (Inches)	Filter Size (mm)	Rated Airflow (CMH)	Initial Resistance (Pa)	Residence Time (Sec)	Carbon Weight (Kg)
24 x 24 x 12	Size: 592 x 592 x 292	1700	50	0.06	12
24 x 20 x 12	Size: 592 x 490 x 292	1200	50	0.06	10
24 x 12 x 12	Size: 592 x 292 x 292	850	50	0.06	6
24 x 24 x 16	Size: 592 x 592 x 400	1700	35	0.08	16
24 x 20 x 16	Size: 592 x 490 x 400	1200	35	0.08	14
24 x 12 x 16	Size: 592 x 292 x 400	850	35	0.08	8
24 x 24 x 17	Size: 592 x 592 x 430	1700	30	0.10	18
24 x 20 x 17	Size: 592 x 490 x 430	1200	30	0.10	16
24 x 12 x 17	Size: 592 x 292 x 430	850	30	0.10	9

Residence time will be half of given above when operated at double airflow.

- Humidity : 95%
- Temperature : 60 ° C
- Please contact factory for special toxic or VOC gases

Disposable Pleated carbon filters

are pleated panels which offers extended surface filtration combined with odor control, designed to suit a wide variety of HVAC applications including Hospitals, Pharmaceutical companies, Food processing units, Restaurants, Airports, Commercial Buildings etc. The filters are available in MERV6 to MERV 13 efficiency with frame depth from 25 mm, 45mm and 95mm depths. These filters are recommended as direct replacements to existing pleated air filters. Filters are easy to install and completely disposable too.



Media Features and Technical Details

The filter media is granulated activated carbon with large surface area sandwiched between 100% Synthetic Filter Media. The pleated media pack is encased in a heavy duty wet strength beverage board frame with diagonal support on both sides. Filter media is bonded to board frames in all sides using adhesive to make the filter 100% leak free. A specially designed finger separator holds the pleats straight offering minimal pressure drop. Metal or plastic frame options also available. Carb Z85 model filters which has an additional MERV 13 / F7 Meltblown layer which enhances the filtration efficiency to NERV13 / F7 grade as per EN 779:2012. Thanks to its unique construction which employs a dual property of odor adsorption as well as fine filtration. We also offer blended media of Activated Carbon and Activated Alumina impregnated to deal with various toxic gases.

Selection Chart ▼

Model Number	Nominal Size (Inches)	Actual Size (mm)
FCZ-24-1	12 x 24 x 1	287 x 592 x 25
FCZ-60-1	16 x 20 x 1	395 x 495 x 25
FCZ-65-1	16 x 25 x 1	395 x 625 x 25
FCZ-00-1	20 x 20 x 1	495 x 495 x 25
FCZ-44-1	24 x 24 x 1	592 x 592 x 25
FCZ-55-1	25 x 25 x 1	625 x 625 x 25
FCZ-24-2	12 x 24 x 2	287 x 592 x 45
FCZ-60-2	16 x 20 x 2	395 x 495 x 45
FCZ-65-2	16 x 25 x 2	395 x 625 x 45
FCZ-00-2	20 x 20 x 2	495 x 495 x 45
FCZ-44-2	24 x 24 x 2	592 x 592 x 45
FCZ-55-2	25 x 25 x 2	625 x 625 x 45
FCZ-24-4	12 x 24 x 4	287 x 592 x 95
FCZ-60-4	16 x 20 x 4	395 x 495 x 95
FCZ-65-4	16 x 25 x 4	395 x 625 x 95
FCZ-00-4	20 x 20 x 4	495 x 495 x 95
FCZ-44-4	24 x 24 x 4	592 x 592 x 95
FCZ-55-4	25 x 25 x 4	625 x 625 x 95
FCZ85-24-2	12 x 24 x 2	287 x 592 x 45
FCZ85-04-2	20 x 24 x 2	490 x 592 x 45
FCZ85-44-2	24 x 24 x 2	592 x 592 x 45
FCZ85-24-4	12 x 24 x 4	287 x 592 x 95
FCZ85-04-4	20 x 24 x 4	490 x 592 x 95
FCZ85-44-4	24 x 24 x 4	592 x 592 x 95

● Please contact factory for non-standard sizes and special toxic gases

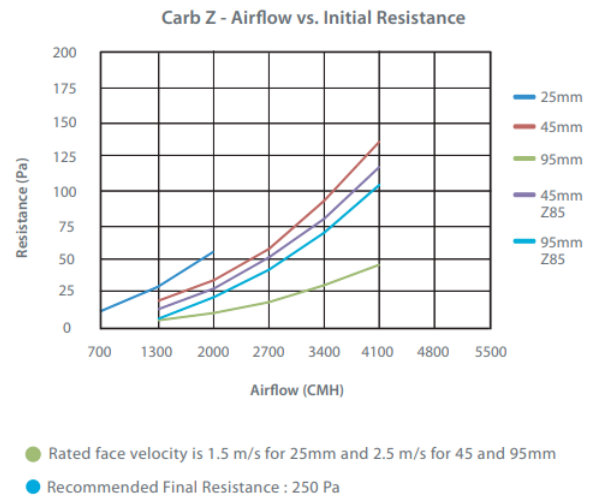

Disposable Honeycomb Carbon Panel Filters

Carb H filters are disposable type panel filters which offers excellent odor filtration, designed to suit a wide variety of HVAC applications including Hospitals, Pharmaceutical companies, Food processing unit, Restaurants, Airports, Commercial Buildings etc. The filters come in 25, 45 and 95mm depths. These filters are used as direct replacements to existing pleated carbon air filters. Filters are easy to install and completely disposable too.



Media Features and Technical Details

The filter media is granulated activated carbon with large surface area arranged in a honeycomb structure. Honeycomb-like activated carbon filter is a new type of adsorption material made by high quality powder activated carbon and binder. It has large amount of through holes from one end to another end in a cubic or cylindrical shaped block. This kind of structure gives low pressure drop, high mechanical strength & more contact surface with gas, with high flow rate, low-concentration VOC pollutant air streams. Filters are encased in Card Board, Metal or Plastic frames. We also offer blended media of Activated Carbon and Activated Alumina impregnated to deal with various toxic gases.

Selection Chart ▼

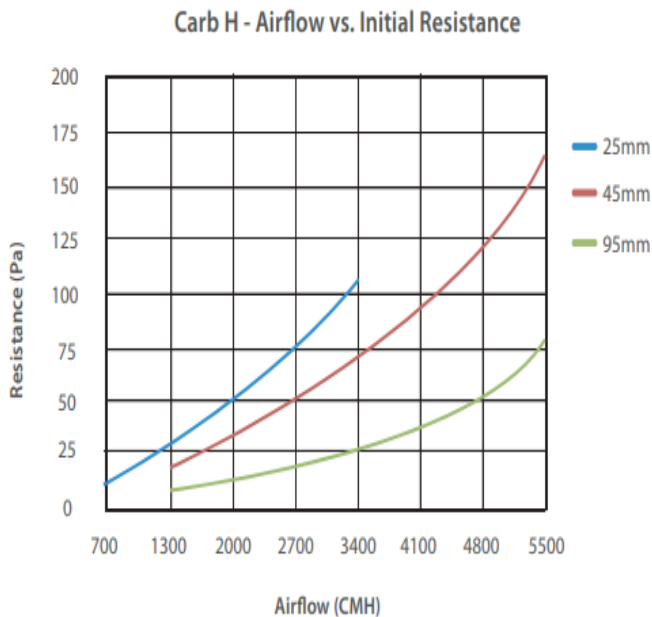

Model Number	Nominal Size (Inches)	Actual Size (mm)
FCH-24-1	12 x 24 x 1	287 x 592 x 25
FCH-60-1	16 x 20 x 1	395 x 495 x 25
FCH-65-1	16 x 25 x 1	395 x 625 x 25
FCH-00-1	20 x 20 x 1	495 x 495 x 25
FCH-44-1	24 x 24 x 1	592 x 592 x 25
FCH-55-1	25 x 25 x 1	625 x 625 x 25
FCH-24-2	12 x 24 x 2	287 x 592 x 45
FCH-60-2	16 x 20 x 2	395 x 495 x 45
FCH-65-2	16 x 25 x 2	395 x 625 x 45
FCH-00-2	20 x 20 x 2	495 x 495 x 45
FCH-44-2	24 x 24 x 2	592 x 592 x 45
FCH-55-2	25 x 25 x 2	625 x 625 x 45
FCH-24-4	12 x 24 x 4	287 x 592 x 95
FCH-60-4	16 x 20 x 4	395 x 495 x 95
FCH-65-4	16 x 25 x 4	395 x 625 x 95
FCH-00-4	20 x 20 x 4	495 x 495 x 95
FCH-44-4	24 x 24 x 4	592 x 592 x 95
FCH-55-4	25 x 25 x 4	625 x 625 x 95

- Rated face velocity is 1.5 m/s for 25mm and 2.5 m/s for 45 and 95mm
- Recommended Final Resistance : 250 Pa
- Please contact factory for non-standard sizes and special toxic gases

Disposable Honeycomb Carbon Panel Filters in metal frames



Carb Tray Refillable Activated Carbon Filter Tray

Refillable metal Trays | for use with activated carbon, impregnated carbon or other chemisorbant media.

(Powder coated carbon steel/ Galvanized or Stainless Steel)

Trays are reusable panel filters that provide long life and excellent odor filtration, designed to suit a wide variety of HVAC applications including Hospitals, Pharmaceutical companies, Food processing units, Restaurants, Airports, Commercial Buildings etc. These comes in 20mm, 25mm and 45mm depths. These filters are used as direct replacements to existing air filters and also used in V Bank arrangements on Odor Control Units where handling of higher flow with high residence time is required.



Side access rear load Housing for 1" thick carbon trays 12" depth

Air flows up to 1000 CFM

MODEL	UNIT SIZE	TRAY SIZE	TRAYS PER UNIT
300	19 ³ / ₈ H X 19 ³ / ₈ W X 11 ⁵ / ₈	10 ⁷ / ₈ X 17 ³ / ₈ X 1	6
350	19 ³ / ₈ H X 23 ³ / ₈ W X 11 ⁵ / ₈	10 ⁷ / ₈ X 21 ⁵ / ₈ X 1	6
350V	23 ³ / ₈ H X 19 ³ / ₈ W X 11 ⁵ / ₈	10 ⁷ / ₈ X 17 ³ / ₈ X 1	8
400HH	11 ³ / ₈ H X 23 ³ / ₈ W X 11 ⁵ / ₈	10 ⁷ / ₈ X 21 ⁵ / ₈ X 1	4
400HV	23 ³ / ₈ H X 11 ³ / ₈ W X 11 ⁵ / ₈	10 ⁷ / ₈ X 9 ³ / ₈ X 1	8
400	23 ³ / ₈ H X 23 ³ / ₈ W X 11 ⁵ / ₈	10 ⁷ / ₈ X 21 ⁵ / ₈ X 1	8
500	23 ³ / ₈ H X 23 ³ / ₈ W X 11 ⁵ / ₈	10 ⁷ / ₈ X 23 ³ / ₈ X 1	8

NOTE: 500 SERIES HAS NO HEADER

NOTE: MODEL SHOWN: 400

SPECIFICATIONS

WEIGHT: HOUSING ONLY 26LBS
 MADE FROM 16 GAUGE CRS
 ALL WELD CONSTRUCTION
 POWDER COAT FINISH
 (OPTIONAL ALUMINIZED STEEL OR STAINLESS STEEL)

UNITS CAN HOLD DISPOSABLE HONEYCOMB TRAYS OR RE-FILLABLE TIN PLATED TRAYS (MUST BE SPECIFIED WHEN ORDERING)

DESIGN VELOCITY: 2000CFM
 MODEL 400 DISPOSABLE TRAYS 0.493" W.G @ 2000 CFM
 MODEL 400 RE-FILLABLE TRAYS 0.77" W.G @ 2000 CFM

TRAY SIZES MEDIA WEIGHT: +/- .10%

TRAY SIZE	REFILLABLE	DISPOSABLE
10 ⁷ / ₈ X 9 ³ / ₈ X 1		
CARBON -	1.77 LBS	1.22 LBS
50/50 POTASSIUM/CARBON -	2.35 LBS	1.37 LBS
POTASSIUM -	2.92 LBS	1.75 LBS
10 ⁷ / ₈ X 17 ³ / ₈ X 1		
CARBON -	3.25 LBS	2.24 LBS
50/50 POTASSIUM/CARBON -	4.31 LBS	2.50 LBS
POTASSIUM -	5.36 LBS	3.35 LBS
10 ⁷ / ₈ X 21 ⁵ / ₈ X 1		
CARBON -	3.99 LBS	2.75 LBS
50/50 POTASSIUM/CARBON -	5.29 LBS	3.08 LBS
POTASSIUM -	6.58 LBS	3.95 LBS
10 ⁷ / ₈ X 23 ³ / ₈ X 1		
CARBON -	4.27 LBS	2.94 LBS
50/50 POTASSIUM/CARBON -	5.65 LBS	3.29 LBS
POTASSIUM -	7.04 LBS	4.22 LBS

DRAWN	12/3/2014	TITLE	400 SERIES	
CHECKED		SIZE	DWG NO	REV
TOLERANCE:	+/- .1/16	C	400 SERIES UNIT	B
SQUARENESS	+/- .1/8	SCALE	SHEET 1 OF 1	

Front or Rear load BOX style housing for 1" thick carbon trays 12" depth

Air flows up to 1000 CFM

MODEL	UNIT SIZE	TRAY SIZE	TRAYS PER
500H-V	11 ³ / ₈ H X 23 ³ / ₈ W X 11 ⁵ / ₈	10 7/8 X 23 1/8 X 1	4
500H	23 ³ / ₈ H X 11 ³ / ₈ W X 11 ⁵ / ₈	10 7/8 X 11 1/8 X 1	8
500	23 ³ / ₈ H X 23 ³ / ₈ W X 11 ⁵ / ₈	10 7/8 X 23 1/8 X 1	8

NOTE: 500 SERIES HAS NO HEADER

SPECIFICATIONS

MADE FROM 18 GAUGE CRS
 STITCH WELDED CONSTRUCTION
 POWDER COAT FINISH I
 (OPTIONAL ALUMINIZED STEEL
 OR STAINLESS STEEL)

UNITS CAN HOLD DISPOSABLE HONEYCOMB TRAYS OR
 REFILLABLE TIN PLATED TRAYS
(MUST BE SPECIFIED WHEN ORDERING)

DESIGN VELOCITY: 2000CFM
 MODEL 500 DISPOSABLE TRAYS
 0.485" W.G @ 2000 CFM
 MODEL 500 REFILLABLE TRAYS
 0.77" W.G @ 2000 CFM

TRAY SIZES MEDIA WEIGHT: +/- 10%

500 UNIT HOLDS 8

TRAY SIZE	WEIGHT PER TRAY	
	REFILLABLE	DISPOSABLE
10 ⁷ / ₈ X 23 ³ / ₈ X 1	4.27 LBS	2.94 LBS
CARBON -	5.65 LBS	3.29 LBS
50/50 POTASSIUM/CARBON -	7.04 LBS	4.22 LBS
POTASSIUM -		

500H UNIT HOLDS 8

TRAY SIZE	WEIGHT PER TRAY	
	REFILLABLE	DISPOSABLE
10 ⁷ / ₈ X 11 ³ / ₈ X 1	2.13 LBS	1.47 LBS
CARBON -	2.82 LBS	1.64 LBS
50/50 POTASSIUM/CARBON -	3.52 LBS	2.11 LBS
POTASSIUM -		

500HV UNIT HOLDS 4

TRAY SIZE	WEIGHT PER TRAY	
	REFILLABLE	DISPOSABLE
10 ⁷ / ₈ X 23 ³ / ₈ X 1	4.27 LBS	2.94 LBS
CARBON -	5.65 LBS	3.29 LBS
50/50 POTASSIUM/CARBON -	7.04 LBS	4.22 LBS
POTASSIUM -		

DRAWN	12/3/2014	TITLE	500 SERIES	
CHECKED		SIZE	C	REV A
TOLERANCE:	+/- .1/16	DWG NO	500	
SQUARENESS	+/- .1/8	SCALE		SHEET 1 OF 1

Front or Rear load BOX style housing for 1" carbon trays 24" depth

Air flows up to 2000 CFM

CFM	FA	PREFILTER	MEDIA TRAYS	POSTFILTER
2000	FRONT ACCESS	2"-4"	1"-2"	2"-4"
MODEL NUMBER:				
2000FA	-1T		1" MEDIA TRAYS	
2000FA	-2T		2" MEDIA TRAYS	
(DEPTH 24 1/2)				
2000FA	2P-1T	2" PREFILTER	1" MEDIA TRAYS	
2000FA	2P-2T	2" PREFILTER	2" MEDIA TRAYS	
(DEPTH 27")				
2000FA	4P-1T	4" PREFILTER	1" MEDIA TRAYS	
2000FA	4P-2T	4" PREFILTER	2" MEDIA TRAYS	
(DEPTH 29")				
2000FA	2P-1T-2P	2" PREFILTER	1" MEDIA TRAYS	2" POSTFILTER
2000FA	2P-2T-2P	2" PREFILTER	2" MEDIA TRAYS	2" POSTFILTER
(DEPTH 29")				
2000FA	4P-1T-4P	4" PREFILTER	1" MEDIA TRAYS	4" POSTFILTER
2000FA	4P-2T-4P	4" PREFILTER	2" MEDIA TRAYS	4" POSTFILTER
(DEPTH 33")				

NOTE: MODEL SHOWN: 2000FA-1T

SPECIFICATIONS

MADE FROM 14 GAUGE CRS
ALL WELDED CONSTRUCTION
POWDER COAT FINISH
(OPTIONAL ALUMINIZED STEEL
OR STAINLESS STEEL)

FILTER OPTIONS:
PRE-POST SIZES:
2" PRE-POST 23 3/8 X 23 3/8 X 1 3/8
4" PRE-POST 23 3/8 X 23 3/8 X 3 3/8

MEDIA FILTER SIZES:
QTY-10 24 X 23 1/8 X 1" MEDIA TRAYS
QTY-8 24 X 23 1/8 X 1 3/8 MEDIA TRAYS

DESIGN VELOCITY: 2000CFM
(W.G NOT INCLUDING PRE OR POST FILTER)
MODEL 2000FA 1T .35" W.G @ 500 FT/MIN
MODEL 2000FA 2T .55" W.G @ 500 FT/MIN

MEDIA WEIGHT: +/- 10%h
1" TRAYS
CARBON - 90LBS
50/50 BLEND POTASUIM/CARBON - 127LBS
POTASUIM - 160LBS
KOH IMPRAGANATED - 108LBS
2" TRAYS
CARBON - 145LBS
50/50 BLEND POTASUIM/CARBON - 190LBS
POTASUIM - 230LBS
KOH IMPRAGANATED - 160LBS

DRAWN	7/1/2010	TITLE	
CHECKED		2000FA	
TOLERANCE:	+/- .1/16	SIZE	REV
SQUARENESS	+/- .1/8	C	
		2000FA HOUSING	
		SCALE	HEET 1 OF 1

Front or Rear load Box style housing ½ size for 1" or 1.88" carbon trays 24" depth

12" height x 24" width

Air Flows up to 1000 CFM at 0.35" w.g. holding 45 pounds of activated carbon

CFM	FA	PREFILTER	MEDIA TRAYS	POSTFILTER
1000	FRONT ACCESS	2"-4"	1T-2T	2" - 4"

MODEL NUMBER:
 H2000FA -1T 1" MEDIA TRAYS
 H2000FA -2T 2" MEDIA TRAYS
 (DEPTH 24 1/2")

H2000FA 2P-1T 2" PREFILTER 1" MEDIA TRAYS
 H2000FA 2P-2T 2" PREFILTER 2" MEDIA TRAYS
 (DEPTH 27")

H2000FA 4P-1T 4" PREFILTER 1" MEDIA TRAYS
 H2000FA 4P-2T 4" PREFILTER 2" MEDIA TRAYS
 (DEPTH 29")

H2000FA 2P-1T-2P 2" PREFILTER 1" MEDIA TRAYS 2" POSTFILTER
 H2000FA 2P-2T-2P 2" PREFILTER 2" MEDIA TRAYS 2" POSTFILTER
 (DEPTH 29")

H2000FA 4P-1T-4P 4" PREFILTER 1" MEDIA TRAYS 4" POSTFILTER
 H2000FA 4P-2T-4P 4" PREFILTER 2" MEDIA TRAYS 4" POSTFILTER
 (DEPTH 33")

NOTE: MODEL SHOWN: H2000FA -1T

SPECIFICATIONS
 MADE FROM 14 GAUGE CRS
 ALL WELDED CONSTRUCTION
 POWDER COAT FINISH
 (OPTIONAL ALUMINIZED STEEL
 OR STAINLESS STEEL)

FILTER OPTIONS:
 PRE-POST SIZES:
 2" PRE-POST 11 3/4" X 23 3/4" X 1 3/4"
 4" PRE-POST 11 3/4" X 23 3/4" X 3 3/4"

MEDIA FILTER SIZES:
 QTY-5 24 X 23 1/4" X 1" MEDIA TRAYS
 QTY-4 24 X 23 1/4" X 1 3/4" MEDIA TRAYS

DESIGN VELOCITY: 1000CFM
 (W.G NOT INCLUDING PRE OR POST FILTER)
 MODEL H2000FA 1T .35" W.G @500 FT/MIN
 MODEL H2000FA 2T .55" W.G @ 500 FT/MIN

MEDIA WEIGHT: +/- 10%b.
 1" TRAYS
 CARBON - 45 LBS
 50/50 BLEND POTASUIM/CARBON - 63.5 LBS
 POTASUIM - 60 LBS
 KOH IMPRAGANATED -54 LBS
 2" TRAYS
 CARBON - 72.5 LBS
 50/50 BLEND POTASUIM/CARBON - 95 LBS
 POTASUIM - 115 LBS
 KOH IMPRAGANATED -60 LBS

DRAWN	7/1/2010	TITLE	
CHECKED		2000H-FA	
TOLERANCE:	+/- .1/16	SIZE	DWG NO
SQUARENESS	+/- .1/8	C	2000H-FA HOUSING
		SCALE	REV
			1

Front or Rear load Box style housing ½ size for 1" or 1.88" thick carbon trays 24" depth

24"Ht x 12" width

Air Flows up to 1000 CFM at 0.35" w.g. holding 45 pounds of activated carbon

CFM	FA	PREFILTER	MEDIA TRAYS	POSTFILTER
1000	FRONT ACCESS	2'-4"	1T- 2T	2' - 4"
MODEL NUMBER:				
	HW 2000FA -1T		1" MEDIA TRAYS	
	HW 2000FA -2T		2" MEDIA TRAYS	
	(DEPTH 24 1/2)			
	HW 2000FA 3P-1T	2" PREFILTER	1" MEDIA TRAYS	
	HW 2000FA 3P-2T	2" PREFILTER	2" MEDIA TRAYS	
	(DEPTH 27")			
	HW 2000FA 4P-1T	4" PREFILTER	1" MEDIA TRAYS	
	HW 2000FA 4P-2T	4" PREFILTER	2" MEDIA TRAYS	
	(DEPTH 29")			
	HW 2000FA 3P-1T-3P	2" PREFILTER	1" MEDIA TRAYS	2" POSTFILTER
	HW 2000FA 3P-2T-3P	2" PREFILTER	2" MEDIA TRAYS	2" POSTFILTER
	(DEPTH 29")			
	HW 2000FA 4P-1T-4P	4" PREFILTER	1" MEDIA TRAYS	4" POSTFILTER
	HW 2000FA 4P-2T-4P	4" PREFILTER	2" MEDIA TRAYS	4" POSTFILTER
	(DEPTH 33")			

NOTE: MODEL SHOWN: HW 2000FA-1T

SPECIFICATIONS

MADE FROM 14 GAUGE CRS
ALL WELDED CONSTRUCTION
POWDER COAT FINISH
(OPTIONAL ALUMINIZED STEEL
OR STAINLESS STEEL)

FILTER OPTIONS
PRE-POST SIZES:
2" PRE-POST 11 3/4" X 23 3/4" X 1 3/4"
4" PRE-POST 11 3/4" X 23 3/4" X 3 3/4"

MEDIA FILTER SIZES:
QTY-10 12 X 23 1/4" X 1" MEDIA TRAYS
QTY-8 12 X 23 1/4" X 1 1/4" MEDIA TRAYS

DESIGN VELOCITY: 1000FPM
(W.G. NOT INCLUDING PRE OR POST FILTER)
MODEL H-2000FA 1T .35" W.G @500 FT/MIN
MODEL H-2000FA 2T .55" W.G @ 500 FT/MIN

MEDIA WEIGHT: +/- 10%
1" TRAYS
CARBON - 45 LBS
50%
70 BLEND POTASUIM/CARBON - 63.5 LBS
POTASUIM - 80 LBS
KOH IMPRAGANATED -54 LBS
2" TRAYS
CARBON - 72.5 LBS
50%
70 BLEND POTASUIM/CARBON - 95 LBS
POTASUIM - 115 LBS
KOH IMPRAGANATED -80 LBS

DRAWN	7/1/2010	TITLE	
CHECKED		2000HV-FA	
TOLERANCE:	+/- 1/16	SIZE	DWG NO
SQUARENESS	+/- .18	C	2000HV-FA HOUSING
		SCALE	REV
			1 OF 1

Front or Rear Load Box Style housing for holding 18" depth carbon modules

Air flows up to 2000 CFM at 0.42" w.g.

(holds up to 60 pounds of activated carbon)

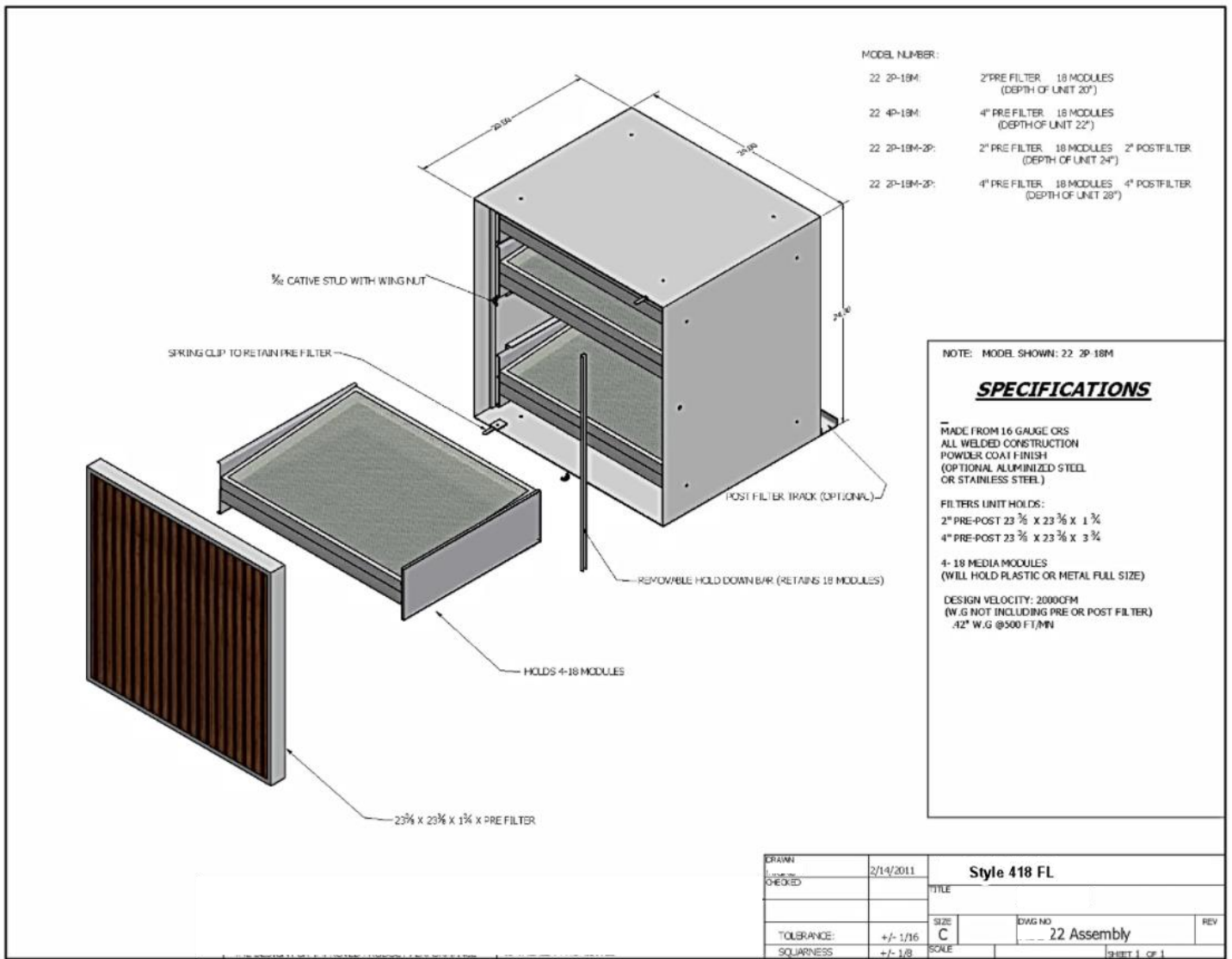

Refillable Activated Carbon V-cells | and modules in metal or plastic

Cells may hold activated carbon in granular or pellets as well as round chemisorbant media.

RS12-Metal (full size)

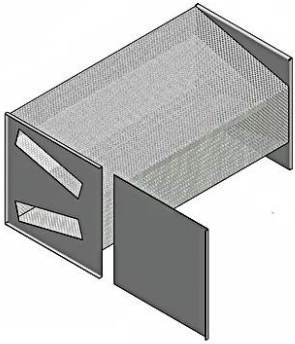

RS12-Plastic (full size)

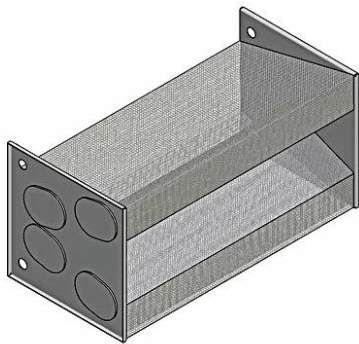

RS18-Metal (full size)

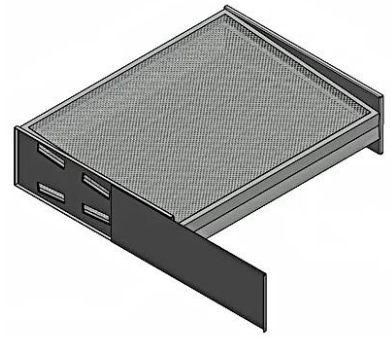

RS12 Metal (half size)

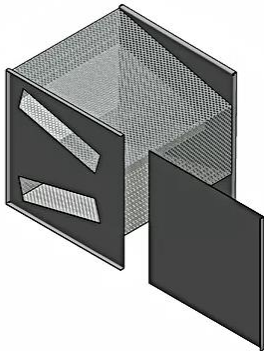

RS12 Plastic (half size)

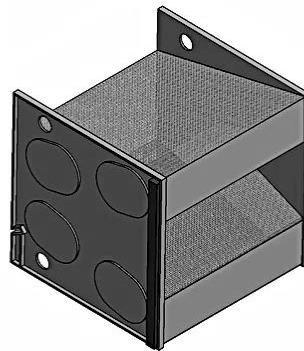

RS18 Metal (half size)

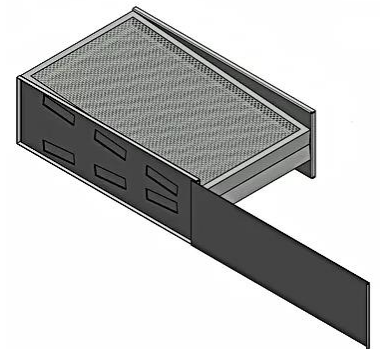

**RS18-Bonded Carbon
(Full size) Disposable**

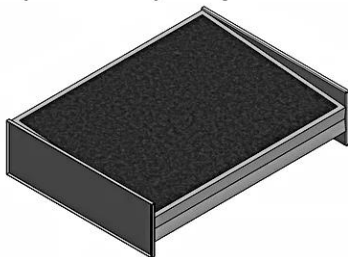

**RS18-Plastic Version
(Full size)**

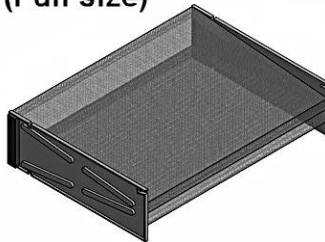

**RS18-Plastic Version
(half size)**

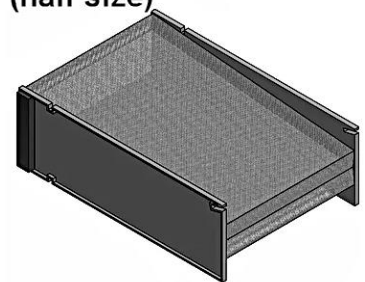

Metal Version

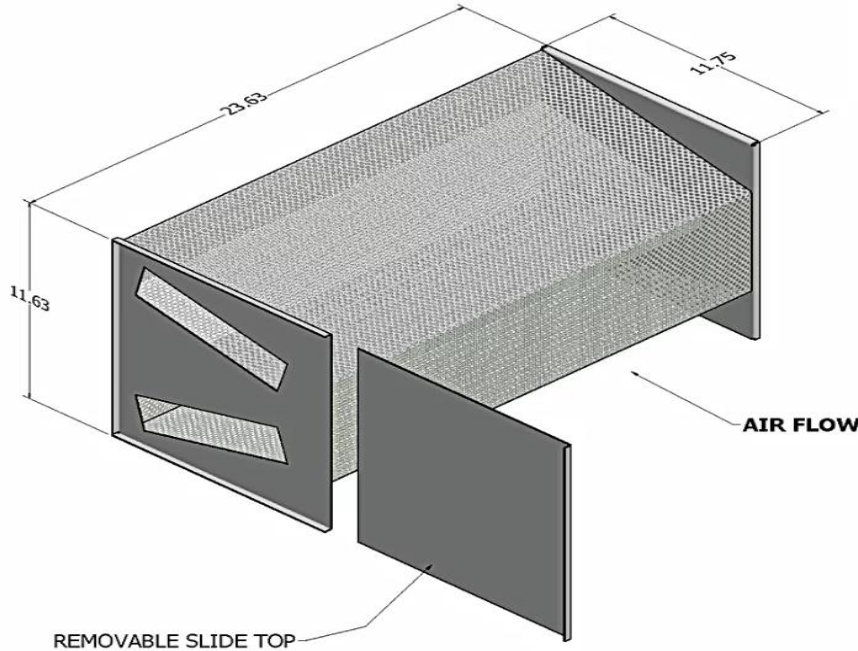

- FILLED WITH 60 CTC COCONUT
- FILLED WITH 50/50 BLEND COCONUT & POTASSIUM
- FILLED POTASSIUM
- FILLED KOH IMPREGNATED

SPECIFICATIONS
DIMENSIONS: 23⁵/₈ X 11³/₈ X 11³/₄
 END PLATES MADE FROM 18 GAUGE CRS
 MADE FROM 26 GAUGE CRS
 PERFORATED METAL .077 HOLE ON 7/64 CENTERS
 ALL WELDED CONSTRUCTION
 POWDER COAT FINISH
 (OPTIONAL ALUMINIZED STEEL OR STAINLESS STEEL)
 DESIGN VELOCITY: 500 CFM
 .89" W.G @250 FT/MN
MEDIA WEIGHT: +/- 5%
 CARBON - 31.5LBS
 50/50 BLEND POTASUIM/CARBON 35.5LBS
 POTASUIM - 50LBS
 KOH IMPRAGANATED -35LBS

DRAWN	7/19/2013	TITLE	12 MF	
CHECKED		SIZE	C	REV B
TOLERANCE:	+/- 1/16	DWG NO	12 MODULE	
SQUARINESS	+/- 1/8	SCALE	SHEET 1 OF 1	

Metal Version

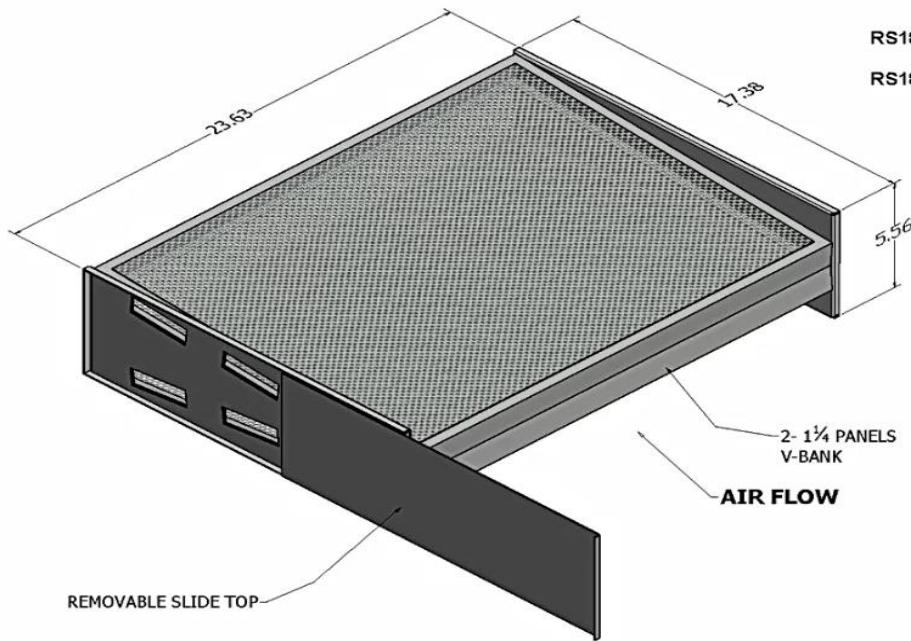

MODEL #

- RS18M-CF FILLED WITH 60 CTC COCONUT
- RS18M-CPF FILLED WITH 50/50 BLEND 60 CTC COCONUT & POTASSIUM
- RS18M-PF FILLED POTASSIUM
- RS18M-KOHF FILLED KOH IMPREGNATED

SPECIFICATIONS
DIMENSIONS: 23⁵/₈ X 17³/₈ X 5⁹/₁₆
 END PLATES MADE FROM 18 GAUGE CRS
 PANELS MADE FROM 26 GAUGE CRS
 PERFORATED METAL .077 HOLE ON 7/64 CENTERS
 ALL WELDED CONSTRUCTION
 POWDER COAT FINISH
 (OPTIONAL ALUMINIZED STEEL OR 304 STAINLESS STEEL)
 DESIGN VELOCITY: 500CFM
 .43" W.G @500 FT/MN
 MEDIA CAPACITY/VOLUME .55 CUBIC FT
MEDIA WEIGHT: +/- 5%
 CARBON - 15LBS
 50/50 BLEND POTASUIM/CARBON 22LBS
 POTASUIM - 25.4LBS
 KOH IMPRAGANATED -18.5LBS

DRAWN	3/15/2010	TITLE	18 MF	
CHECKED		SIZE	C	REV B
TOLERANCE:	+/- 1/16	DWG NO	18 MODULE	
SQUARINESS	+/- 1/8	SCALE	SHEET 1 OF 1	

Plastic Version

PART SIZE PER SET	RATED AIR FLOW CFM	RESISTANCE W.G	MEDIA TYP	MEDIA WEIGHT PER SET
11 $\frac{1}{8}$ " X 23 $\frac{3}{8}$ " X 11 $\frac{1}{4}$ "	500	.72	60CTC PELLET	34.5LBS +/-5%
11 $\frac{5}{8}$ " X 23 $\frac{3}{8}$ " X 11 $\frac{1}{4}$ "	500	.72	50% BLEND PELLET/POTASSIUM	39.7LBS +/-5%
11 $\frac{5}{8}$ " X 23 $\frac{3}{8}$ " X 11 $\frac{1}{4}$ "	500	.72	POTASSIUM	49.8LBS +/-5%
11 $\frac{5}{8}$ " X 23 $\frac{3}{8}$ " X 11 $\frac{1}{4}$ "	500	.72	KOH IMPREG.	45.4LBS +/-5%

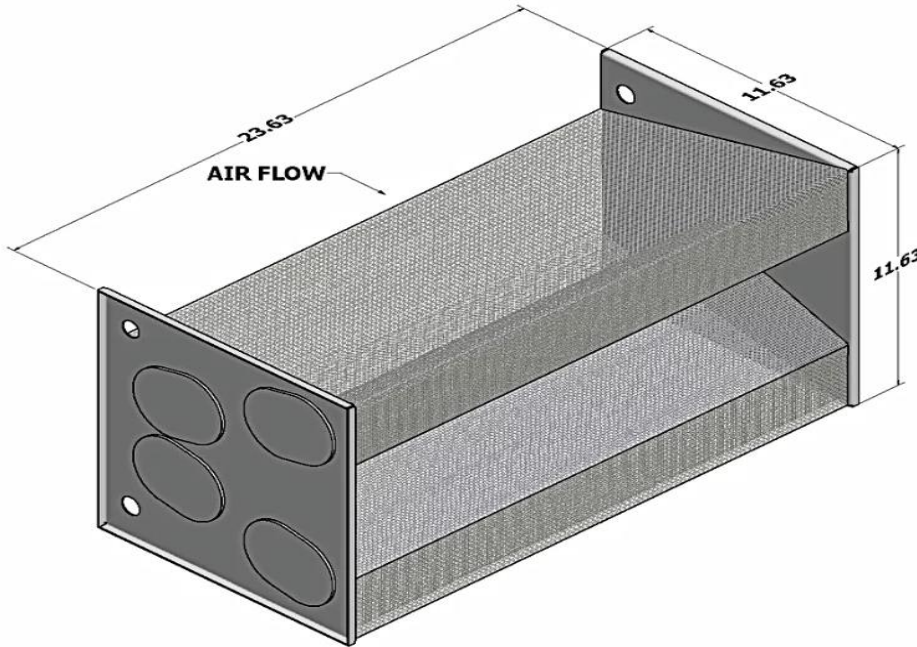

SPECIFICATIONS

MADE FROM .100 POLYSTYRENE PLASTIC
ALL GLUED CONSTRUCTION
.056 X .500 SLOTTED PERF
NON REMOVABLE PLUGS
MODULE IS INCINERABLE
MODULES SOLD IN SETS OF TWO
PRESSURE DROP
.72 @ 500CFM
ALL MEDIA WEIGHT IS +/- 5%

SIDE ACCESS LOAD SYSTEMS
MODULES ARE RECOMMENDED TO HAVE FOAM ON SIDE FOR PROPER SEAL

DRAWN	3/16/2011	TITLE	12PF
CHECKED		SIZE	C
TOLERANCE:	+/- 1/16	DWG NO	12PF
SQUARENESS	+/- 1/8	SCALE	

METAL Version- 1/2 Size

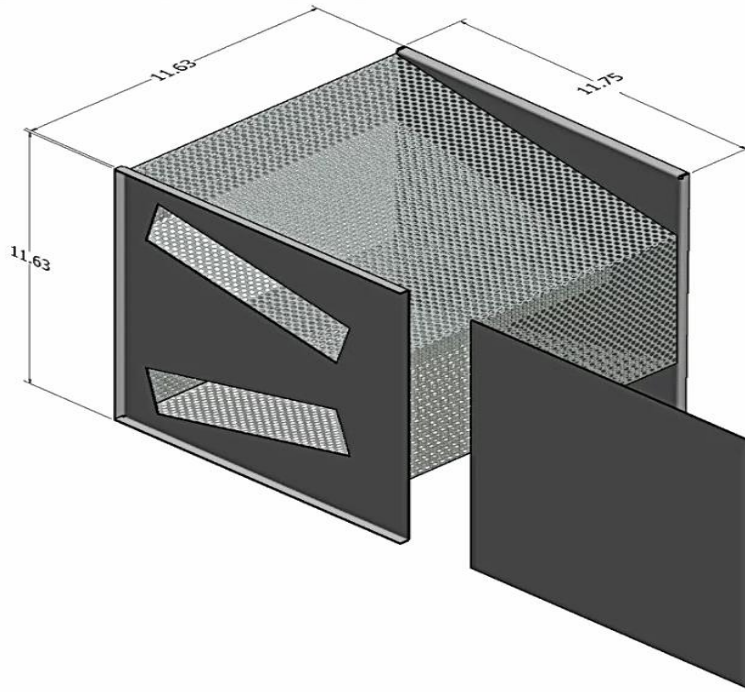

MODEL

RS12MH-CF	FILLED WITH 60 CTC COCONUT
RS12MH-CPF	FILLED WITH 50% BLEND COCONUT & POTASSIUM
RS12MH-PF	FILLED POTASSIUM
RS12MH-KOHF	FILLED KOH IMPREGNATED

SPECIFICATIONS

DIMENSIONS: 11 5/8" X 11 5/8" X 11 3/4"

END PLATES MADE FROM 18 GAUGE CRS

MADE FROM 26 GAUGE CRS
PERFORATED METAL .077 HOLE ON 3/4" CENTERS

ALL WELDED CONSTRUCTION

POWDER COAT FINISH
(OPTIONAL ALUMINIZED STEEL OR STAINLESS STEEL)

DESIGN VELOCITY: 125 CFM
.89" W.G @250 FT/MIN

MEDIA WEIGHT: +/- 5%

CARBON - 15LBS

50/50 BLEND POTASSIUM/CARBON - 21LBS

POTASSIUM - 25LBS

KOH IMPREGNATED -17.5LBS

DRAWN	12/14/2015	TITLE	12 MH
CHECKED		SIZE	C
TOLERANCE:	+/- 1/16	DWG NO	12MH
SQUARENESS	+/- 1/8	SCALE	

Metal Cell- 1/2 Size

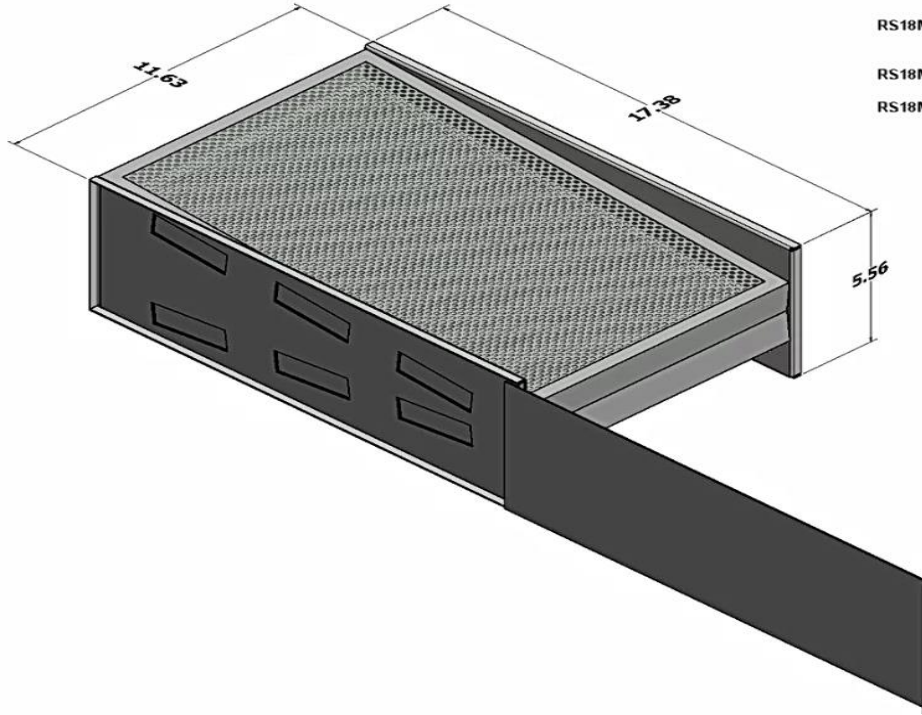

MODEL #

- RS18MH-CF FILLED WITH 60 CTC COCONUT
- RS18MH-CPF FILLED WITH 50/50 BLEND 60 CTC COCONUT & POTASSIUM
- RS18MH-PF FILLED POTASSIUM
- RS18MH-KOHF FILLED KOH IMPREGNATED

SPECIFICATIONS

DIMENSIONS: 11⁵/₈ X 17³/₈ X 5⁵/₁₆

END PLATES MADE FROM 18 GAUGE CRS
 PANELS MADE FROM 26 GAUGE CRS
 PERFORATED METAL .077 HOLE ON 7/64 CENTERS

ALL WELDED CONSTRUCTION

POWDER COAT FINISH
 (OPTIONAL ALUMINIZED STEEL OR 304 STAINLESS STEEL)

DESIGN VELOCITY: 500CFM
 .43" W.G @500 FT/MN

MEDIA WEIGHT: +/- 5%

CARBON - 7.5LBS

50/50 BLEND POTASSIUM/CARBON 11LBS

POTASSIUM - 12.2LBS

KOH IMPRAGANATED -9.25LBS

DRAWN	3/15/2010	TITLE	18 MH	REV	B
CHECKED		SIZE	C	DWG NO	18 HALF METAL MODULE
TOLERANCE:	+/- .1/16	SCALE		SHEET 1 OF 1	
SQUARINESS	+/- .1/8				

PART NUMBER	PART SIZE PER SET	RATED AIR FLOW CFM	RESISTANCE W.G	MEDIA TYP	MEDIA WEIGHT PER SET
RS12PH-CF	11 ⁵ / ₈ X 23 ¹ / ₂ X 11 ⁵ / ₈	500	.72	60CTC PELLET	28LBS +/-5%
RS12PH-CPF	11 ⁵ / ₈ X 23 ¹ / ₂ X 11 ⁵ / ₈	500	.72	50/50 BLEND PELLET/POTASSIUM	38LBS +/-5%
RS12PH-PF	11 ⁵ / ₈ X 23 ¹ / ₂ X 11 ⁵ / ₈	500	.72	POTASSIUM	48LBS +/-5%
RS12PH-KOHF	11 ⁵ / ₈ X 23 ¹ / ₂ X 11 ⁵ / ₈	500	.72	KOH IMPREG.	30LBS +/-5%
RS12PH-CP8F	11 ⁵ / ₈ X 23 ¹ / ₂ X 11 ⁵ / ₈	500	.72	50/50 BLEND PELLET/POTASSIUM 8"	40LBS +/-5%

Plastic Version-Set

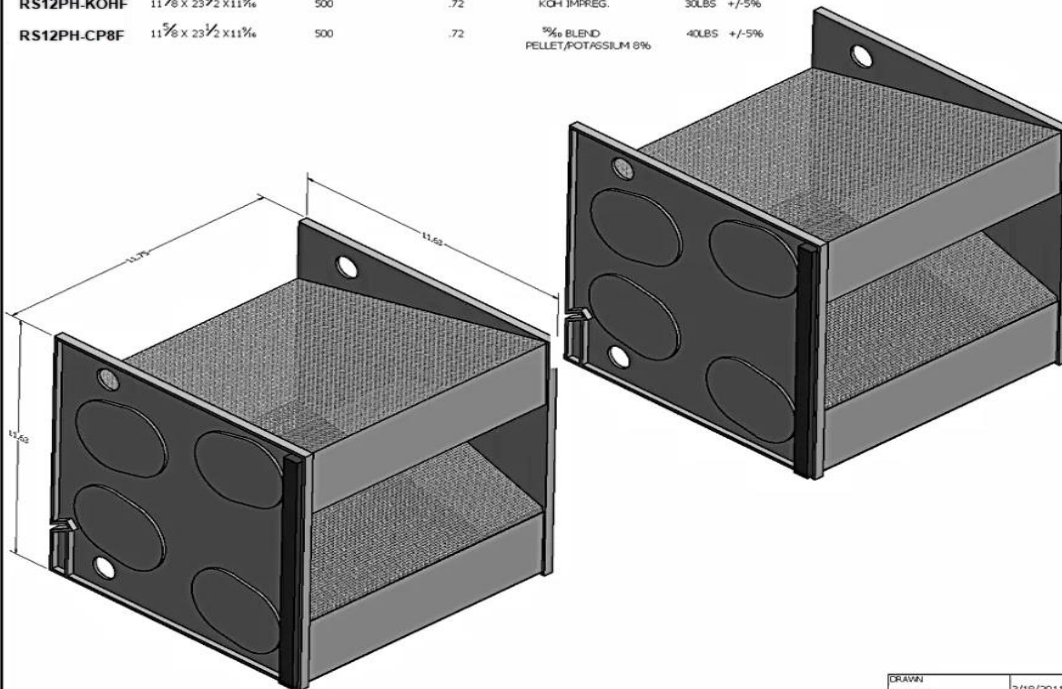

NOTE: MODEL SHOWN: ONE SET

SPECIFICATIONS

MADE FROM .100 POLYSTYRENE PLASTIC
 ALL GLUED CONSTRUCTION

.056 X .500 SLOTTED PERF

NON REMOVABLE PLUGS

MODULE IS INCINERABLE

MODULES SOLD IN SETS OF TWO

PRESSURE DROP
 .72 @ 500CFM

ALL MEDIA WEIGHT IS +/- 5%

SIDE ACCESS LOAD SYSTEMS
 MODULES ARE RECOMMENDED TO HAVE FOAM ON SIDE FOR PROPER SEAL

DRAWN	3/16/2011	TITLE	12PH	REV	B
CHECKED		SIZE	C	DWG NO	12PH
TOLERANCE:	+0 -1/16	SCALE		SHEET 1 OF 1	
SQUARINESS	+/- .1/16				

RS18-Plastic

PART NUMBER	PART SIZE PER SET	RATED AIR FLOW CFM	RESISTANCE W.G	MEDIA TYP	MEDIA WEIGHT PER SET
RS18P-CF	5 $\frac{1}{8}$ x 23 $\frac{3}{8}$ x 17 $\frac{3}{8}$	500	.55	60CTC PELLET	12.2 LBS +/-10%
RS18P-CPF	5 $\frac{1}{8}$ x 23 $\frac{3}{8}$ x 17 $\frac{3}{8}$	500	.55	90% BLEND PELLET/POTASSIUM	16 LBS +/-10%
RS18P-PF	5 $\frac{1}{8}$ x 23 $\frac{3}{8}$ x 17 $\frac{3}{8}$	500	.55	POTASSIUM	18.8 LBS +/-10%
RS18P-KOH	5 $\frac{1}{8}$ x 23 $\frac{3}{8}$ x 17 $\frac{3}{8}$	500	.55	KOH IMPREG.	15LBS +/-10%

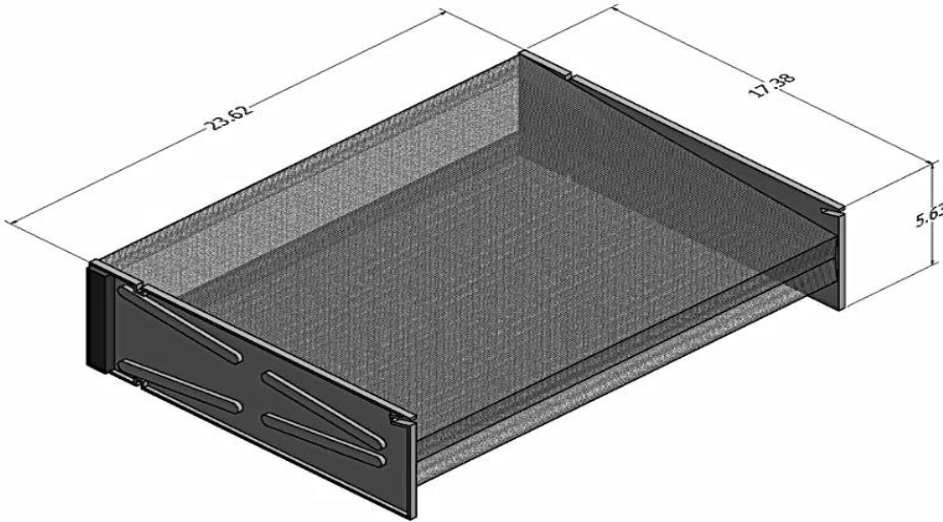

NOTE: MODEL SHOWN: ONE

SPECIFICATIONS
 MADE FROM POLYCARBONITE PLASTIC
 .080X .500 SLOTTED PERF
 MODULE IS INCINERABLE
 PRESSURE DROP
 .55 @ 500CFM
 ALL MEDIA WEIGHT IS +/- 10%

SIDE ACCESS LOAD SYSTEMS
 MODULES ARE RECOMMENDED TO HAVE FOAM ON SIDE FOR
 PROPER SEAL

DRAWN	30/4/2010	TITLE	18PF	
CHECKED		SIZE	C	REV
TOLERANCE:	+0 / - 1/8	DWG NO		
SQUARNESS	+/- 1/16	SCALE	PLASTIC @ FULL SIZE POLYCARBONITE	
			SHEET 1 OF 1	

RS18- Bonded Carbon full size- disposable

MODEL #	
RS18-BCD	FILLED WITH 60 CTC COCONUT
RS18-BKOH	FILLED KOH IMPREGNATED

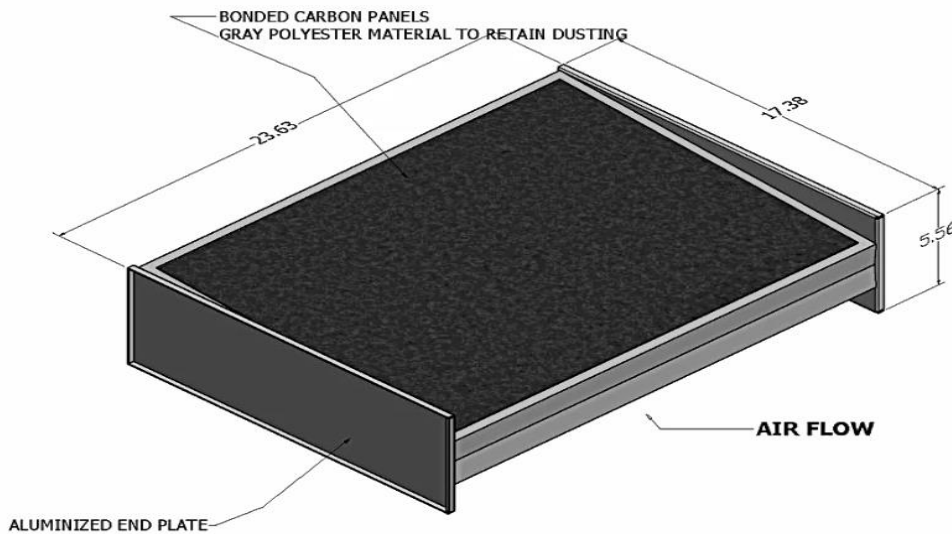

SPECIFICATIONS

DIMENSIONS: 23 $\frac{3}{8}$ X 17 $\frac{3}{8}$ X 5 $\frac{9}{16}$
 END PLATES MADE FROM 18 GAUGE ALUMINIZED
 SCREWED / RIVET CONSTRUCTION

DESIGN VELOCITY: 500CFM
 .43" W.G @500 FT/MIN

MEDIA WEIGHT: +/- 10%
 CARBON - 15.5LBS
 KOH-impregnated -18.5LBS

DRAWN	3/15/2010	TITLE	18FB	
CHECKED		SIZE	C	REV
TOLERANCE:	+/- 1/16	DWG NO		
SQUARNESS	+/- 1/8	SCALE	18F BONDED MODULE	
			SHEET 1 OF 1	

RS18-Plastic half size

PART NUMBER	PART SIZE PER SET	RATED AIR FLOW CFM	RESISTANCE W.G	MEDIA TYP	MEDIA WEIGHT PER SET
RS18PH-CF	5 $\frac{1}{8}$ x 23 $\frac{1}{4}$ x 17 $\frac{3}{8}$	500	.55	60CTC PELLETT	13.0LBS +/-5%
RS18PH-CPF	5 $\frac{1}{8}$ x 23 $\frac{1}{4}$ x 17 $\frac{3}{8}$	500	.55	5% BLEND PELLETT/POTASSIUM	15.2LBS +/-5%
RS18PH-PF	5 $\frac{1}{8}$ x 23 $\frac{1}{4}$ x 17 $\frac{3}{8}$	500	.55	POTASSIUM	21.9LBS +/-5%
RS18PH-KOHF	5 $\frac{1}{8}$ x 23 $\frac{1}{4}$ x 17 $\frac{3}{8}$	500	.55	PELLETT KOH IMPREG.	14.9LBS +/-5%

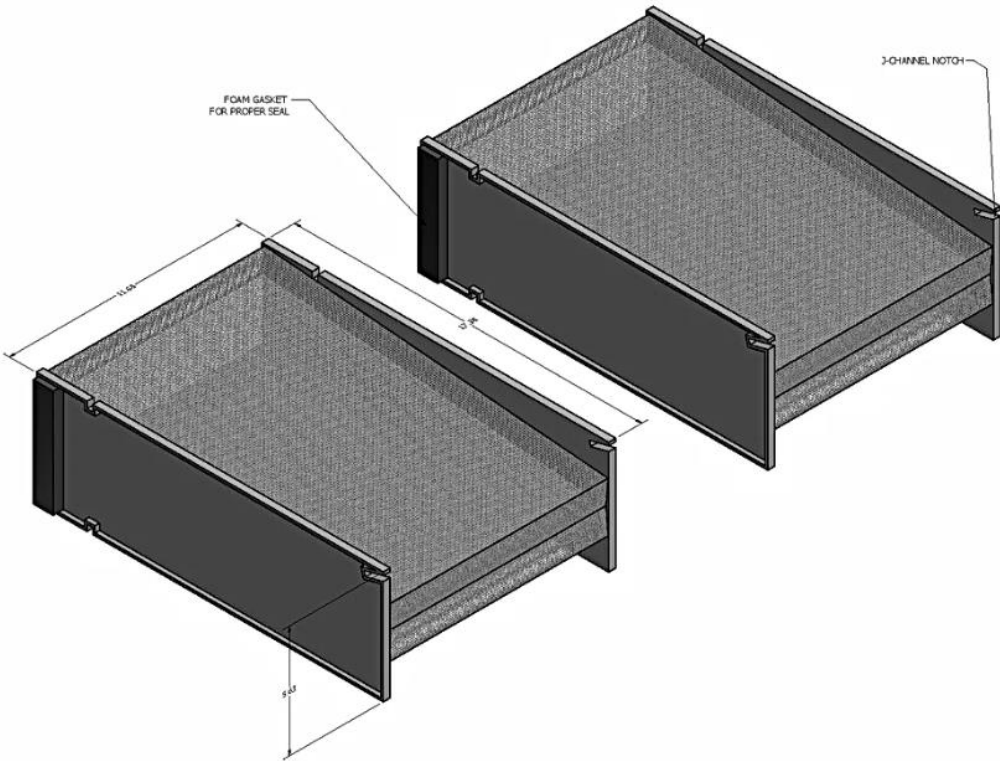

NOTE: MODEL SHOWN: ONE SET

SPECIFICATIONS

MADE FROM POLYCARBONATE

.000 X .000 SLOTTED PERF

MODULE IS INCOMBUSTIBLE

MODULES SOLD IN SETS OF TWO

PRESSURE DROP
.55 @ 500CFM

ALL MEDIA WEIGHT IS +/- 5%

SIDE ACCESS LOAD SYSTEMS
MODULES ARE RECOMMENDED TO HAVE FOAM ON SIDE FOR PROPER SEAL

DRAWN	10/4/2010	TITLE		REV
CHECKED		18PH		
TOLERANCE:	+0 / - 1/16	SIZE	DWG NO	
SQUARNESS	+/- 1/16	C	18PH	
		SCALE	SHEET 1 OF 1	

The 8" depth V-cell

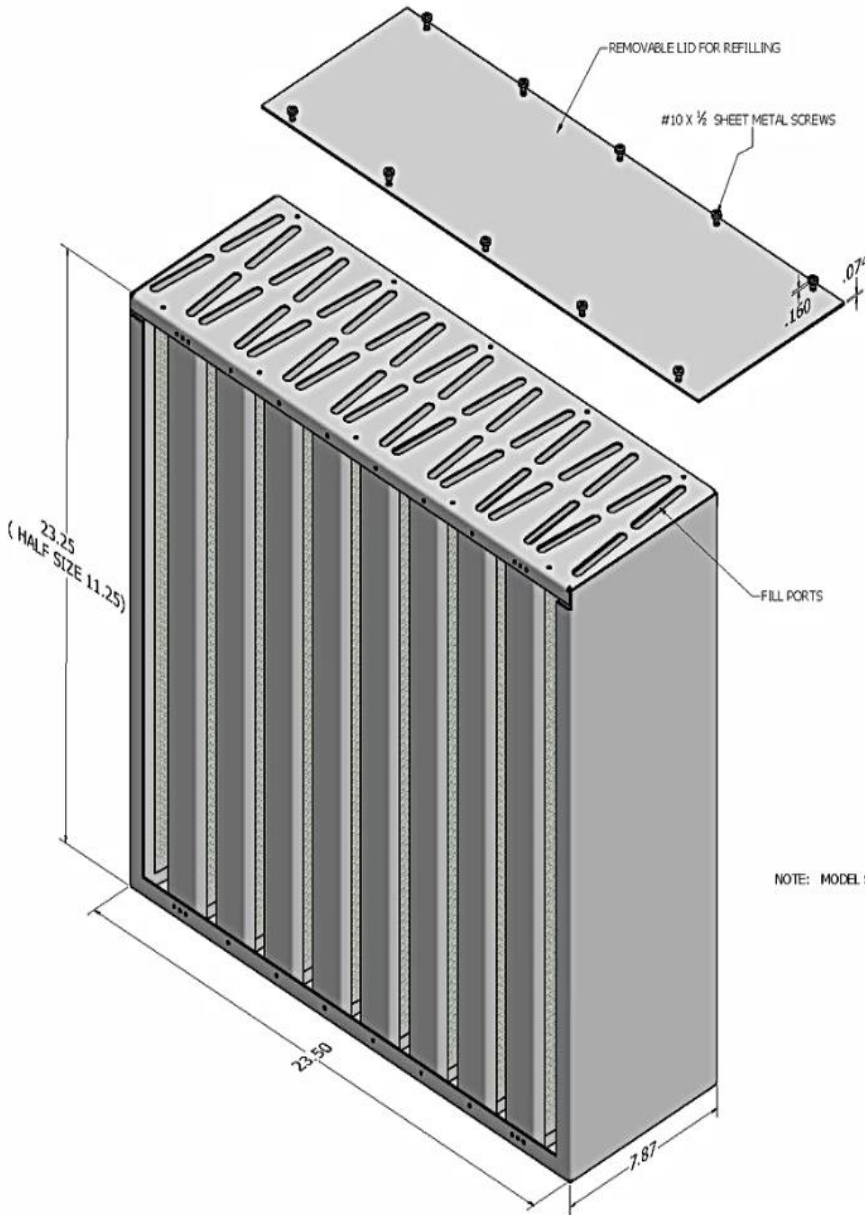

NOTE: MODEL SHOWN: ESM FULL SIZE

PART #	SIZE	MATERIAL	MEDIA
99-3-01-17-01-ESM	23½ X 23½ X 7½	CRS PAINTED	EMPTY
99-3-01-17-02-ESM	23½ X 23½ X 7½	CRS PAINTED	STANDARD CARBON
99-3-01-17-25-ESM	23½ X 23½ X 7½	CRS PAINTED	50% BLEND (CARBON/POTASSIUM)
99-3-09-17-01-ESM	23½ X 23½ X 7½	ALUMINIZED	EMPTY
99-3-09-17-02-ESM	23½ X 23½ X 7½	ALUMINIZED	STANDARD CARBON
99-3-09-17-25-ESM	23½ X 23½ X 7½	ALUMINIZED	50% BLEND (CARBON/POTASSIUM)
99-3-02-17-01-ESM	23½ X 23½ X 7½	304 STAINLESS	EMPTY
99-3-02-17-02-ESM	23½ X 23½ X 7½	304 STAINLESS	STANDARD CARBON
99-3-02-17-25-ESM	23½ X 23½ X 7½	304 STAINLESS	50% BLEND (CARBON/POTASSIUM)

HALF SIZE MODULE

99-3-01-17-01-ESMH	11½ X 23½ X 7½	CRS PAINTED	EMPTY
99-3-01-17-02-ESMH	11½ X 23½ X 7½	CRS PAINTED	STANDARD CARBON
99-3-01-17-25-ESMH	11½ X 23½ X 7½	CRS PAINTED	50% BLEND (CARBON/POTASSIUM)
99-3-09-17-01-ESMH	11½ X 23½ X 7½	ALUMINIZED	EMPTY
99-3-09-17-02-ESMH	11½ X 23½ X 7½	ALUMINIZED	STANDARD CARBON
99-3-09-17-25-ESMH	11½ X 23½ X 7½	ALUMINIZED	50% BLEND (CARBON/POTASSIUM)
99-3-02-17-01-ESMH	11½ X 23½ X 7½	304 STAINLESS	EMPTY
99-3-02-17-02-ESMH	11½ X 23½ X 7½	304 STAINLESS	STANDARD CARBON
99-3-02-17-25-ESMH	11½ X 23½ X 7½	304 STAINLESS	50% BLEND (CARBON/POTASSIUM)

SPECIFICATIONS

MADE FROM 16 GAUGE CRS
WELDED AND RIVETED CONSTRUCTION
POWDER COAT FINISH
(OPTIONAL ALUMINIZED STEEL
OR STAINLESS STEEL)

FULL SIZE :
DESIGN VELOCITY: 1000CFM
W.G .30 @ 250 FPM

MEDIA WEIGHT: +/- 5%
CARBON - 40LBS
50/
50 BLEND POTASSIUM/CARBON - 45LBS
POTASSIUM - 53LBS

HALF SIZE :
DESIGN VELOCITY: 500CFM
W.G .30 @ 250 FPM

MEDIA WEIGHT: +/- 5%
CARBON - 20LBS
50/
50 BLEND POTASSIUM/CARBON - 22.5LBS
POTASSIUM - 26.5LBS

TITLE ESM MODULE

Hydroponics | Refillable Canisters

Filled with Virgin Activated Carbon



Detailed Product Description

Flange Size:	6 Inch	Material:	Galvanized Sheet
Carbon Type:	Granular Carbon	Filtration Efficiency:	95%
Service Life:	1.5-3 Years	CTC:	55%

Removes all smells/odors when used with fan through activated carbon.

-The professional grade carbon filters(50MM carbon bed depth) in a variety of sizes to fit 4" 5 " 6" 8 " 10" 12 "fans.

-53% Open area custom mesh for maximum airflow.

-100% Virgin activated carbon, 4mm pelletized carbon or light granulated carbon.

- Aluminum flanges are light weight, and it looks beautiful. The colors available are usually silver, light green, light pink or can be other colors for OEM orders.

- Pre filter set is included

-1.5 to 3 year life span.

ITEM	Configuration Size F.D.*T1*T2	Carbon bed depth mm	granulated Carbon weight kg	N.W./G.W. (KG)	MAX AIRFLOW m3/h
4"-150MM	4"X150MM*200MM	50	1.23	2.4/2.75	280
4"-200MM	4"X200MM*250MM	50	1.5	2.75/3.1	370
4"-250MM	4"X250MMX300MM	50	1.9	3.2/3.7	470
4"-300MM	4"X300MMX350MM	50	2.4	3.75/4.3	560
4"-400MM	4"X350MMX400MM	50	3.2	4.6/5.1	750
4"-450MM	4"X450MMX500MM	50	3.7	5.1/5.6	840
4"-500MM	4"X500MMX550MM	50	4.2	5.6/6.2	940
4"-550MM	4"X550MMX600MM	50	4.6	6.2/6.9	1030
4"-600MM	4"X600MMX650MM	50	5.1	6.7/7.4	1120
5"-200MM	5"X200MMX250MM	50	2.3	3.4/4.1	400
5"-250MM	5"X250MMX300MM	50	2.87	4/4.7	500
5"-300MM	5"X300MMX350MM	50	3.45	4.6/5.2	600
5"-400MM	5"X400MMX450MM	50	4.6	5.8/6.8	1200
5"-450MM	5"X450MMX500MM	50	5.3	6.6/7.5	1350
5"-500MM	5"X500MMX550MM	50	5.75	7.1/8	1500
5"-600MM	5"X600MMX650MM	50	6.9	8.3/9.1	1800
6"-250MM	6"X250MMX300MM	50	3.1	4/5.1	530
6"-300MM	6"X300MMX350MM	50	3.65	4.6/5.7	640
6"-350MM	6"X350MMX400MM	50	4.2	5.52/6.5	750
6"-400MM	6"X400MMX450MM	50	4.8	6.5/7.3	850
6"-450MM	6"X450MMX500MM	50	5.4	7.6/8.4	960
6"-500MM	6"X500MMX550MM	50	6	8.7/9.9	1070
6"-550MM	6"X550MMX600MM	50	6.6	9.8/11.1	1170
6"-600MM	6"X600MMX650MM	50	7.3	10.9/12.2	1280
6"-950MM	6"X950MMX1000MM	50	11.6	15.7/17.2	2030
6"-1000MM	6"X1000MMX1050MM	50	12.3	16.9/18.4	2130
8"-350MM	8"X350MMX400MM	50	5.4	8.1/8.8	830
8"-400MM	8"X400MMX450MM	50	6.2	9.4/10.6	950
8"-450MM	8"X450MMX500MM	50	7	9.4/10.6	1070
8"-500MM	8"X500MMX550MM	50	7.9	10.6/12.2	1190
8"-600MM	8"X600MMX650MM	50	9.3	11.8/13.3	1425
8"-1000MM	8"X1000MMX1050MM	50	15.6	17.7/19.3	2375
10"-550MM	10"X550MMX600MM	50	8.9	11.7/13.3	1510
10"-600MM	10"X550MMX600MM	50	11	11.7/13.3	1650
10"-950MM	10"X950MMX1000MM	50	17.5	23.7/25.5	2610
10"-1000MM	10"X1000MMX1050MM	50	18.45	21.5/23.5	2750
12"-500MM	12"X500MMX550MM	50	10.3	12.5/13.6	1600
12"-600MM	12"X600MMX650MM	50	12.4	15/16.3	1920
12"-950MM	12"X950MMX1000MM	50	19.7	27/28.6	3040
12"-1000MM	12"X1000MMX1050MM	50	20.8	28.8/30.5	3200
12"-1150MM	12"X1150MMX1200MM	50	24	34/35.9	3680
12"-1200MM	12"X1200MMX1250MM	50	25	35.6/37.7	3840

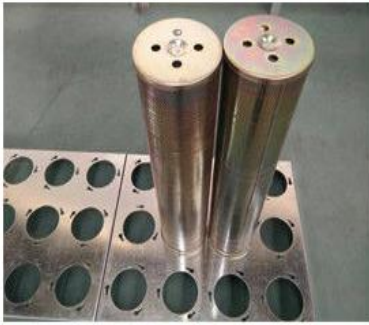

Detailed Product Description

Filter Length:	600mm	Filter Diameter:	145mm
Carbon Bed Depth:	26mm	Filter Mesh:	53% Open Area
Carbon Packing:	Vibro Machine	Anti Static Treatment:	Yes

1. Application for ventilation of airport, railway station, metro, commercial building, pharmaceutical, electrics,
2. chemical, food, beverage, kitchen, oil smoke,
3. Common specification 145x450mm, 145x 600mm;
4. 145mm, 160mm diameter;
5. Virgin carbon pellet
6. 26mm-28mm carbon bed depth;
7. Filter mesh provide large filtration area;
8. Light weight and max air flow
9. Easy and fast installation

Model	Dimension (mm)	Carbon layer thickness (mm)	Carbon content (kg)	Total weight (kg)	resistance@air volume (Pa@m3/h)
	Diameter x Length				
CF-330	Φ145×330	28.5	1.37	3.27	135@225
CF-405	Φ145×405	28.5	1.72	3.82	110@225
CF-450	Φ145×450	28.5	1.88	4.08	100@225
CF-480	Φ145×480	28.5	2.1	4.5	90@225
CF-500	Φ145×500	28.5	4.6	5.1	85@225
CF-600	Φ145×600	28.5	2.5	5.2	70@225

Air Filtration | Rotating Equipment / Gas Turbine

Intake filters available from MERV 12 to MERV15 and Higher efficiencies to HEPA grades H12 or H13. The high efficiency Mini-Pleat compact filters made up of water resistant micro-fine glass fiber media Or Synthetic media are available in a wide range of efficiencies from MERV 12 to MERV 16 (65% - 95%+). V cells are designed for use in Gas Turbine installations where highest degree of air cleanliness is required. The compact design, larger surface area and low initial resistance made it an Ideal alternative to ordinary Bag filters & Box type filters of the similar efficiencies. V-Cell compact filter models are also available with very high burst resistance, low pressure drop and high dust holding capacity for extreme operating conditions like Gas turbine air intake fine filtration etc. VGT Models are available with plastic grid support optional. The Header style is available in 12", 16" or 17" depths with 20 or 25mm header. Filters are absolutely metal free and so are incinerable and environmentally friendly. Filters can also be made in Reverse flow design.



V Cell - Mini Pleat Compact Filters (glass media)

V-Cell, the high efficiency Mini-Pleat compact filters made up of micro-fine glass fiber media are available in a wide range of efficiencies from MERV 12 to HEPA E12 grade. V-cells are designed for use in HVAC installations where highest degree of air cleanliness is required. The compact design, large surface area and low initial resistance made it an ideal alternative to ordinary Bag filters & Box type filters of the similar efficiencies. V Cell models are also available with very high burst resistance, low pressure drop and high dust holding capacity for extreme operating conditions like Gas Turbine air intake filtration. GTV Models are with plastic grid support.

V-Cell standard model is constructed in plastic frame with 11.5" depth and are available in 20 and 25mm headers

4V filters are made up of water resistant micro-fine glass fiber filter media, closely pleated and separated by continuous thermo-plastic bead separators. This design accommodates a very large quantity of filter media which offers a longer service life and low pressure drop. The Mini-Pleated media packs are arranged in perfect V design and sealed to the enclosing frame. Single piece foam gasket will be provided upon request.

GTV-Gas Turbine Models are constructed in plastic frame and are backed with Heavy duty plastic mesh support for additional protection.

The GTV model utilizes a special grade media offering very high dust holding capacity and the mini-pleat packs are backed with an additional plastic grid support for each media panel to ensure protection during operation in harsh conditions. Fully Potted versions are also available. Filters are absolutely metal free and are incinerable and environmentally friendly. Filters can also be made in Reverse flow design. These filters offer very high burst pressure, and are ideal for extreme operating conditions.



ASHRAE 52.2-2012	Standard Model	GT Model	Size Inches (Nominal)	Media Area Sq.ft.	Rated Airflow CFM	Initial Resistance In W.G.	Final Resistance In W.G.
MERV 15/ F9	4VF94412	4VGTF94412	24 x 24 x 12	196	2000	.51	2.5
MERV 15/ F9	4VF90412	4VGTF90412	20 x 24 x 12	162	1600	.51	2.5
MERV 15/ F9	4VF94212	4VGTF94212	12 x 24 x 12	98	1000	.51	2.5
MERV 14/ F8	4VF84412	4VGTF84412	24 x 24 x 12	196	2000	.285	2.5
MERV 14/ F8	4VF80412	4VGTF80412	20 x 24 x 12	162	1600	.285	2.5
MERV 14/ F8	4VF84212	4VGTF84212	12 x 24 x 12	98	1000	.285	2.5
MERV 13/ F7	4VF74412	4VGTF74412	24 x 24 x 12	196	2000	.26	2.5
MERV 13/ F7	4VF70412	4VGTF70412	20 x 24 x 12	162	1600	.26	2.5
MERV 13/ F7	4VF74212	4VGTF74212	12 x 24 x 12	98	1000	.26	2.5
MERV12/M6	4VM64412	4VGTM64412	24 x 24 x 12	196	2000	.22	2.5
MERV12/M6	4VM60412	4VGTM60412	20 x 24 x 12	162	1600	.22	2.5
MERV12/M6	4VM64212	4VGTM64212	12 x 24 x 12	98	1000	.22	2.5

All data are average indicative values with usual manufacturing and testing tolerances. We reserve the right to modify performance data without prior notices due to the constant technical improvement.

H4V Cell - HEPA Mini Pleat Compact Filters

V HEPA GT filters are the new generation type of high efficiency Mini-Pleat compact HEPA filters available in a wide range of efficiencies from E10 to E12 based on EN1822 Test standards. DOP Ratings from 95%, 98% and 99.97%.

4V HEPA filters are designed to use in HVAC installations where highest degree of air cleanliness is required. The high burst resistance, low pressure drop and high dust holding capacity offered by the filter made it an ideal filter for extreme operating conditions like Gas turbine air intake fine filtration. This filter perfectly suits the third stage filtration levels in Gas Turbines after a normal pre filter and medium Efficiency MERV 13 to MERV 15 fine filter depending on the applications.

Media Features and Technical Details

V HEPA GT filters are made up of water resistant micro-fine glass fiber media closely pleated and separated using hot melt bead separators which gives a unique V configuration to the pleats and accommodates a very large quantity of filter media. The Mini-Pleated media packs are arranged in a perfect V design in a robust enclosing frame made up of plastic. Filters are fully glued with polyurethane for complete air tightness. These filters come with PU Foam single piece gasket to ensure a 100% leak free installation.

The H4V model filters utilizes a special grade media offering very high dust holding capacity and the mini-pleat packs are backed with an additional plastic grid support for each media panels to ensure protection during operation at harsh conditions. Filters are absolutely metal free and so are incinerable and environmentally friendly. Made in a light weight design, these filters work well for humid and salt laden environments. Low energy versions featuring high media area are available.



Efficiency EN1822	Initial Efficiency MPPS / DOP	Part No.	Size Inches (Nominal)	Size Actual	Rated Airflow CFM	Initial Resistance In W.G.
E10	≥ 85% / 95%	H4VE10-4412	24 x 24 x 12	23.3 x 23.3 x 11.5	2000	0.55
E10	≥ 85% / 95%	H4VE10-4212	24 x 12 x 12	23.3 x 11.3 x 11.5	1000	0.55
E11	≥ 95% / 98%	H4VE11-4412	24 x 24 x 12	23.3 x 23.3 x 11.5	2000	0.63
E11	≥ 95% / 98%	H4VE11-4212	24 x 12 x 12	23.3 x 11.3 x 11.5	1000	0.63
E12	≥ 99.5% / 99.97%	H4VE12-4412	24 x 24 x 12	23.3 x 23.3 x 11.5	2000	0.80
E12	≥ 99.5% / 99.97%	H4VE12-4212	24 x 12 x 12	23.3 x 11.3 x 11.5	1000	0.80

- Recommended Final Resistance : 2.4" W.G.
- Maximum Final Resistance : 3.2" W.G.
- Continuous Operating Temperature : 160 ° F
- Maximum Relative Humidity : ≥ 100
- Static Burst Pressure (New Filter) : 20" W.G.
- Dynamic Burst Pressure (New Filter) : 20" W.G.

All data are average indicative values with usual manufacturing and testing tolerances. We reserve the right to modify performance data without prior notices due to the constant technical improvement.

V Cell –16XL and 17XXL GT

Mini Pleat Compact Filters (glass media)

V-Cell, the high efficiency Mini-Pleat compact filters made up of micro-fine glass fiber media are available in a wide range of efficiencies from MERV 12 to HEPA E12 grade. V-cells are designed for use in HVAC installations where highest degree of air cleanliness is required. The compact design, large surface area and low initial resistance made it an ideal alternative to ordinary Bag filters & Box type filters of the similar efficiencies. V Cell models are also available with very high burst resistance, low pressure drop and high dust holding capacity for extreme operating conditions like Gas Turbine air intake filtration. GT Models are with plastic grid support and fully potted.

V- XL / XXL filters are made up of water resistant micro-fine glass fiber filter media, closely pleated and separated by continuous thermo-plastic bead separators. The Mini-Pleated media packs are arranged in a perfect V design and sealed to the enclosing frame. The VGT model filters utilizes a special grade media offering very high dust holding capacity and the mini-pleat packs are backed with an additional plastic grid support for each media panel to ensure protection during operation at harsh conditions. Fully Potted versions are also available. Filters are absolutely metal free and so are incinerable and environmentally friendly. Filters can also be made in Reverse flow design. These filters offer very high burst pressure for extreme operating conditions like Gas turbine air intake applications.

VGT-Gas Turbine Models are constructed in plastic frame and are backed with Heavy duty plastic mesh support for additional protection.



ASHRAE 52.2-2012 / EN779 : 1822	Standard Model	GT Model	Size Inches (Nominal)	Rated Airflow (CMH)		Initial Resistance (Pa)		Final Resistance (Pa)
E12	4V12-4416XL	4VGT12-4416	24 x 24 x 16	3400	4250	165	200	635
MERV 16/E11	4V11-4416XL	4VGT11-4416	24 x 24 x 16	3400	4250	155	190	635
MERV 16/E10	4V10-4416XL	4VGT10-4416	24 x 24 x 16	3400	4250	118	155	635
MERV 15/ F9	4VF94416	4VGTF94416	24 x 24 x 16	3400	4250	88	125	635
MERV 14/ F8	4VF84416	4VGTF84416	24 x 24 x 16	3400	4250	83	110	635
MERV 13/ M7	4VM74416	4VGTF84416	24 x 24 x 16	3400	4250	78	100	635
MERV 12/ M6	4VM64416	4VGTM64416	24 x 24 x 16	3400	4250	63	90	635
E12	4VE12-4417	4VGTE12-4417	24 x 24 x 17	3400	4250	160	195	635
MERV 16/E11	4VE11-4417	4VGTE11-4417	24 x 24 x 17	3400	4250	150	185	635
MERV16/E10	4VE10-4417	4VGTE10-4417	24 x 24 x 17	3400	4250	115	150	635
MERV15/F9	4VF94417	4VGTF94417	24 x 24 x 17	3400	4250	85	120	635
MERV14/F8	4VF84417	4VGTF84417	24 x 24 x 17	3400	4250	80	105	635
MERV13/M7	4VM74417	4VGTM74417	24 x 24 x 17	3400	4250	75	95	635
MERV12/M6	4VM64417	4VGTM64417	24 x 24 x 17	3400	4250	60	85	635

4V BOX style - Mini Pleat Plastic V Bank Fine Filters

High to Medium efficiency 4V Box style are mini pleated high velocity filters. These filters operate at very air flow rates up to 3000 CFM and are considered the best replacements for conventional box style fine filters. This also features plastic frame construction and so is a “metal free” filter that is fully incinerable. HVP are available in 4V and 2V configuration ranging from MERV12, 13, 14 and 15. The V shaped arrangement allows more air flow per filter than a standard filter replacement and can save up to 30% on energy. Filters are light weight and its fully plastic body makes it incinerable as well.

Very high approach velocity @ 3.75 m/s (738 FPM)

Available in ISO ePM 10 65%/M6 to ISO ePM 1 85%/F9 grades.
ASHRAE 52.2 grades MERV 12, 13, 14 and 15



Food Grade Plastic Frames

Light weight and incinerable

Available in 4V and 2V designs

MEDIA FEATURES AND TECHNICAL DETAILS

HVP filters are manufactured from continuous length superior quality micro glass fiber paper media available in various efficiencies. The filter media is moisture resistant and fire retardant. All Mini-Pleat fine and absolute filters HVP consist of Computer controlled spacing pleated media, using thermosetting beads. The pleat separation allows optimum media utilization and offers very low pressure drops. Mini pleated panels are arranged in a V configuration to allow maximum reception of air. They are encased in a food grade ABS frame and available in both 4V and 2V configuration for Fine particle HVP range. 2V versions are offered as an economical version or where the required face velocity is lower than 295FPM. The pleated media pack is encapsulated into the filter frame with high density fire retardant urethane. A flat profile neoprene gasket or a one-piece seamless urethane gasket is used as leak free seal to the filter housing.

Filter size (actual size)	4V Design : Air Flow Max 3000 CFM Flow Rate CFM / Pressure drop In. W.G.				
	CFM	MERV12	MERV13	MERV 14	MERV 15
ASHRAE 52.2					
EN779		M6	F7	F8	F9
ISO 16890		ePM10 60%	ePM2.5 65%	ePM1 75%	EPM1 85%
24 x 24 x 11.5	3000	0.46	0.562	0.60	0.62
12 x 24 x 11.5	1470	0.46	0.562	0.60	0.62
23.3 x 23.3 x 11.5	2825	0.46	0.562	0.60	0.62
11.3 x 23.3 x 11.5	1412	0.46	0.562	0.60	0.62

Filter size (actual size)	2V Design : Air Flow Max 2100 CFM Flow Rate CFM / Pressure drop In. W.G.				
	CFM	MERV12	MERV13	MERV 14	MERV 15
ASHRAE 52.2					
EN779		M6	F7	F8	F9
ISO 16890		ePM10 60%	ePM2.5 65%	ePM1 75%	EPM1 85%
24 x 24 x 11.5	2120	0.42	0.52	0.54	0.582
12 x 24 x 11.5	1060	0.42	0.52	0.54	0.582
23.3 x 23.3 x 11.5	2000	0.42	0.52	0.54	0.582
11.3 x 23.3 x 11.5	1000	0.42	0.52	0.54	0.582

6V BOX style HEPA- Mini Pleat Plastic V Bank Filters

HEPA HVP are mini pleated box style high velocity HEPA filters. These filters operate at very high air Volume and are considered the best replacements for conventional HEPA filters. This also features plastic frame construction and so is a “metal free” filter which is incinerable. HVP are available in 6V, 4V and 2V configuration ranging from ISO 15E to ISO 50H grades.

HEPA HVP

Very high approach velocity

Available in ISO 15E/E10, 25E/E11, 40H/H13, 50H/H14 Plastic Frames Light weight and incinerable

6V, 4V and 2V



MEDIA FEATURES AND TECHNICAL DETAILS

Filter Media

HEPA HVP filters are manufactured from continuous length superior quality micro glass fiber paper media available in various efficiencies. The filter media is moisture resistant and fire retardant. The uniform and closed pleat filter pack provides an exceptionally high surface to hold the very fine dusts.

Filter Frames The standard frame construction is food grade ABS and strong enough to withstand clamping force.

Sealant & Gaskets The pleated media pack is encapsulated into the filter frame utilizing a high density fire retardant urethane elastomer. A flat profile neoprene gasket or a one-piece seamless urethane gasket is used to ensure a leak free seal to the filter housing.

Media Separators The Mini-Pleat absolute filters HEPA HVP consist of closely pleated media, computer controlled spacing using thermosetting beads. This type of pleat separation allows optimum media utilization and offers very low pressure drops.

Filter Testing The finished filters undergoes a thorough quality check. Scan tested individually to ensure a leak proof performance and each filter is labeled showing the scan test result on it. We have the testing facilities as per ISO 29463, DIN EN1822 and American Standard IEST-RPCC001.3. Testing of filters can be done according to the customer’s request.

Filter size (actual size)	6V Design : Air Flow CFM Flow Rate CFM / Pressure drop In. W.G.			
	ISO15E/E10 95% DOP	ISO25E/E11 98% DOP	ISO40/H13 99.99%	ISO50H/H14 99.99%
	CFM @ 0.5" W.G.		CFM @ 1" W.G.	
24 x 24 x 11.5	2400	2240	2400	1880
12 x 24 x 11.5	1200	1100	1200	950
23.3 x 23.3 x 11.5	2200	2120	2200	1750
11.3 x 23.3 x 11.5	1100	1060	1100	875

Filter size (actual size)	4V Design : Air Flow CFM low Rate CFM / Pressure drop In. W.G.			
	ISO15E/E10 95% DOP	ISO25E/E11 98% DOP	ISO40/H13 99.99%	ISO50H/H14 99.99%
	CFM @ 0.5" W.G.		CFM @ 1" W.G.	
24 x 24 x 11.5	1700	1600	1700	1350
12 x 24 x 11.5	850	800	850	680
23.3 x 23.3 x 11.5	1500	1400	1500	1200
11.3 x 23.3 x 11.5	750	700	750	600

6V BOX style HV and SHV HEPA- V Bank Filters

HEPA **HV** and **SHV** are mini pleated box style high velocity HEPA filters. These filters operate at very high air Volume and are considered the best replacements for conventional HEPA filters. These feature Metal frame construction with stamped entry and exit for greater strength and a perfect alignment every time. Available in Galvanized or Extruded Aluminum construction. Efficiency grades ranging from ISO 15E to ISO 50H grades.



HEPA HV rated 2000 CFM @ 1.0”w.g.

HEPA SHV rated 2400 CFM @ 1.0”w.g.

Very high approach velocity

Available in ISO 15E/E10, 25E/E11, 40H/H13, 50H/H14

MEDIA FEATURES AND TECHNICAL DETAILS

Filter Media

HEPA HV and SHV filters are manufactured from continuous length superior quality micro glass fiber paper media available in various efficiencies. The filter media is moisture resistant and fire retardant. The uniform and closely pleated filter pack provides an exceptionally high surface to hold the very fine dusts.

Filter Frames The one piece stamped entry and exit standard frame construction provides strength to withstand clamping force. Gel seal style Extruded alum frame is also available.

Sealant & Gaskets The pleated media pack is encapsulated into the filter frame utilizing a high density fire retardant urethane elastomer. A flat profile neoprene gasket or a one-piece seamless urethane gasket is used to ensure a leak free seal to the filter housing.

Media Separators The Mini-Pleat absolute filters **HEPA SHV** and **HV** consist of closely pleated media, computer controlled spacing using thermosetting beads. This type of pleat separation allows optimum media utilization and offers very low pressure drops.

Filter Testing The finished filters undergoes a thorough quality check. Scan tested individually to ensure a leak proof performance and each filter is labeled showing the scan test result on it. We have the testing facilities as per ISO 29463, DIN EN1822 and American Standard IEST-RPCC001.3. Testing of filters can be done according to the customer’s request.

Filter size (actual size)	SHV Design : Air Flow CFM Flow Rate CFM / Pressure drop In. W.G.			
	ISO15E/E10 95% DOP	ISO25E/E11 98% DOP	ISO40/H13 99.99%	ISO50H/H14 99.999
	CFM @ 0.5” W.G.		CFM @ 1” W.G.	
24 x 24 x 11.5	2400	2240	2400	1880
12 x 24 x 11.5	1200	1100	1200	950
23.3 x 23.3 x 11.5	2200	2120	2200	1750
11.3 x 23.3 x 11.5	1100	1060	1100	875
	HV Design : Air Flow CFM Flow Rate CFM / Pressure drop In. W.G.			
ISO29463/ EN1822 IEST-RP-CC- 001.3	ISO15E/E10 95% DOP	ISO25E/E11 98% DOP	ISO40/H13 99.99%	ISO50H/H14 99.999
	CFM @ 0.5” W.G.		CFM @ 1” W.G.	
24 x 24 x 11.5	1700	1600	2000	1550
12 x 24 x 11.5	850	800	1000	680
23.3 x 23.3 x 11.5	1500	1400	1500	1200
11.3 x 23.3 x 11.5	750	700	750	600

Hydrophobic Prefilter Panel filters 2", 4" and 6" thickness

HYDRO PLEAT filters are a new generation filter that replaces conventional coalescer filters. Hydro pleat filters are offered in G4 and M5 efficiency grades. A new generation hydrophobic Synthetic Media with a special coating offers 100% removal of water mist from the air combined with a G4/M5 filtration efficiency is an ideal pre-filter for AHUs and Gas Turbine Intake systems operating in high humid environments like offshore installations. Hydro pleat is a 100% coalescer filter which can challenge any competitive brands.

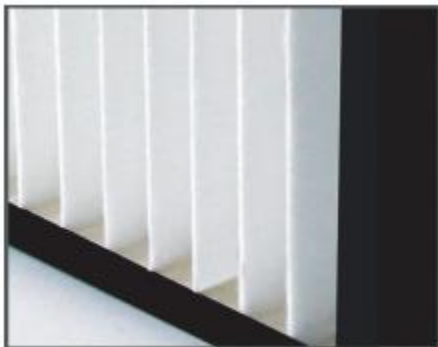

Polyurethane Potting



Plastic Separators



Plastic Grid on ALS

Media Features and Technical Details

- 100% polyester nonwoven media with special hydrophobic treatment
- Cleanable filter media, Low Initial pressure drop
- Total Metal free construction, so 100% incinerable
- Polystyrene Frame, Mesh support & Pleat Separators give rigidity
- Polyurethane potting assures zero air bypass & burst strength

Selection Chart ▼

Filter Model	HPZ4-2	HPZ4-4
Depth (mm)	48	96
Grade: EN 779 / Eurovent	G4	G4
Ave. Dust Spot Eff.	25-30%	25-30%
Ave. Arrestance	94%	94%
Face Velocity (m/s)	2.5	2.5
Initial Resist. (Pa)	70	60
Final Resist. (Pa)	250	250

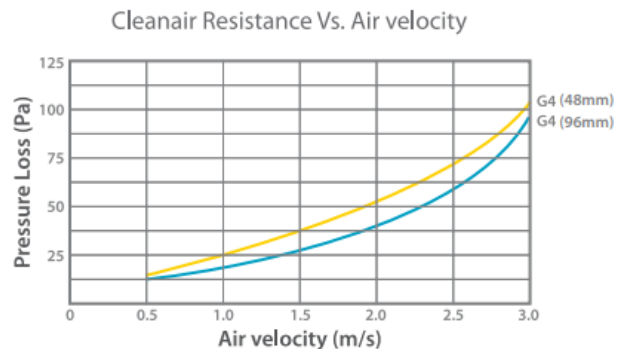

Pro-Clean POLY-PLEAT filters are cleanable / washable panel filters made up of non woven, high lofted synthetic (polyester) filter media and are available in various efficiency grades ranging from G2 to F5. POLY PLEAT filters offer very high dust holding capacity combined with lower resistance than the other types of similar grade panel filters.



Cleanair Resistance Vs. Air velocity

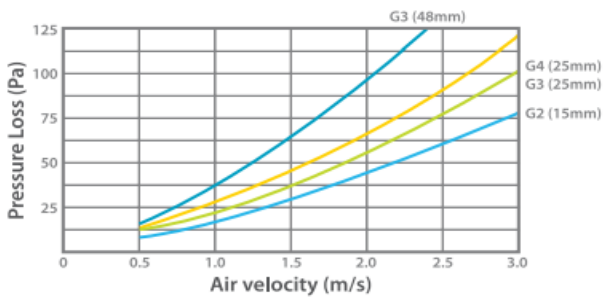

Model: FPG

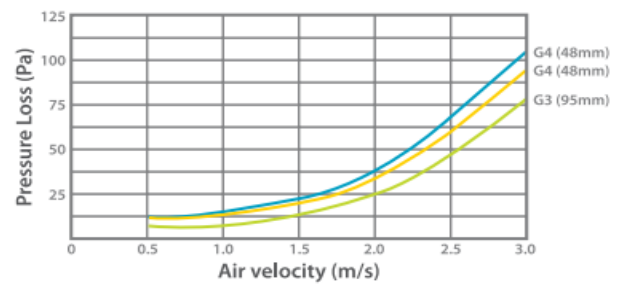

Model: FFP

Technical Data

Filter Model	FPG3	FPG4	FPG5	FPG3-2	FPG3-2	FPG4-2	FPG3-4	FPG4-4
Depth (mm)	25	25	25	48	48	48	94	94
Grade: EN 779 / Eurovent	G3	G4	F5	G3	G3	G4	G3	G4
Ave. Dust Spot Eff.	20-25%	25-30%	45-50%	<20%	20-25%	25-30%	20-25%	25-30%
Ave. Arrestance	91%	94%	95%	83%	91%	94%	91%	94%
Face Velocity (m/s)	1.5/2.5	1.5/2.5	1.5	1.5	2.5	2.5	2.5	2.5
Initial Resist. (Pa)	32 / 72	40 / 90	15	60	60	70	48	58
Final Resist. (Pa)	250	250	450	200	250	250	250	250

CleanPac P - Stiff pocket filter– polyester media

CleanPac-P filters are medium to high efficiency extended surface self-supporting Pocket (bag) filters made of super fine synthetic (Polyester) filter media. The progressive density multi-layered fiber arrangement offers excellent filtration performance combined with very high dust holding capacity. CleanPac-P is Ideal for air intake applications in Automotive paint booths, powder coating and other surface treatment plants . This is also used in air conditioning systems in Hospitals, Pharmaceutical plants, food processing plants, electronic manufacturing facilities etc. With a unique aerodynamic design, this is also available for air intake applications like gas turbines, diesel generators.



Media Features & Technical Details

CleanPac-P, self-supporting bag filters are made up of superior grade synthetic filter media, multi-layered having a progressive density fiber arrangement. This results in high dust holding capacity, low pressure drop and longer lifetime. The rigid pockets are formed by welded construction and aerodynamic design. The pockets are mechanically fastened in an ABS frame. This construction ensures 100% leak proof operation. CleanPac P Filters are completely metal free and are designed to withstand high burst pressure tested up to 25 inches water gauge. These filters can operate well in 100% humid conditions and in salt-laden environments.

Selection Data

Nominal Size (mm)	No.of Pockets	Air flow (CMH)		Initial Resistance to Air flow (Pa)												Media Area (Sq.M)
		Med	High	30%/G3/EU3		40%/G4/EU4		55%/F5/EU5		65%/F6/EU6		85%/F7/EU7		95%/F8/EU8		
				CPP3		CPP4		CPP5		CPP6		CPP7		CPP8		
				Med	High	Med	High	Med	High	Med	High	Med	High	Med	High	
592 x 592 x 300	6	3400	4250	28	50	35	63	40	70	2.42
490 x 592 x 300	5	2550	3400	28	50	35	63	40	70	2.01
292 x 592 x 300	3	1700	2125	28	50	35	63	40	70	1.21
592 x 592 x 380	6	3400	4250	25	48	30	58	38	65	3.02
490 x 592 x 380	5	2550	3400	25	48	30	58	38	65	2.51
292 x 592 x 380	3	1700	2125	25	48	30	58	38	65	1.51
592 x 592 x 600	6/8*	3400	4250	23	43	28	50	35	60	60	95	120	150	130	163	4.82 / 6.46
490 x 592 x 600	5/6*	2550	3400	23	43	28	50	35	60	60	95	120	150	130	163	4.02 / 4.82
292 x 592 x 600	3/4*	1700	2125	23	43	28	50	35	60	60	95	120	150	130	163	2.41 / 3.21
592 x 592 x 660	6/8*	3400	4250	20	35	23	38	30	48	50	80	110	140	115	145	5.23 / 6.98
490 x 592 x 660	5/6*	3400	4080	20	35	23	38	30	48	50	80	110	140	115	145	4.36 / 5.23
292 x 592 x 660	3/4*	2125	2550	20	35	23	38	30	48	50	80	110	140	115	145	2.62 / 3.49

Air Filtration Reverse Pulse Cartridges and Pleated bags

For Dust Collectors Cartridge, Conical, Flange style, Oval, pleated bag style.
Spunbond polyester, Nano applied media, Membrane media, Safety Final Filters.

Pulse Cartridges available from MERV 12 to High Efficiency E12 ratings with Nanofiber. Medias perform day in and day out in some of the toughest turbine environments on earth. From the frigid cold, to scorching heat, and salt laden costal applications we have filters to take care of your application. Superior Nanofiber treated cellulose blends or synthetic bases in efficiencies from F8-E10+. Hydro and oleophobic nanofiber stops fine salt particulate and even low surface tension liquids from penetrating.

Air Inlet Self-Cleaning (pulsed) OR (static) Filtration Systems, one conical and one cylindrical filter are often paired and mounted horizontally to provide turbine protection. The conical and cylindrical pair is typical in many systems.

F9 Synthetic Filter Media

F9 Synthetic Filter Media - Hydrophobic Treated

MERV 16 Cellulose Blended Filter Media

F8 and F9 Cellulose Blended Filter Media

Cartridge Styles

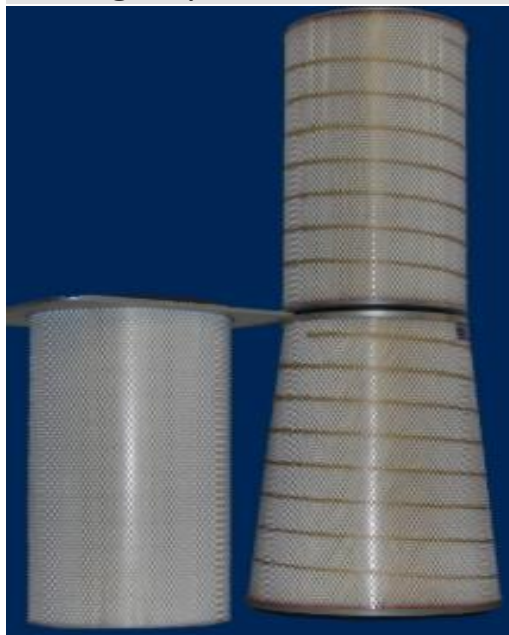

Pleated Bags/Top Load



Dust Collector Replacement Cartridges

Revised 3/18/2020

OEM Model No.	CLS Part #	Media Type	Description	OD"	ID"	Length"	List Price
American Air Filter							
125-1525856-001	DCC1525856	Poly/Cellulose	Open/Closed with Bolt Hole	7.925	3.61	22	\$84.38
134-1569656	DCC1569656	Poly/Cellulose	Open/Closed with Bolt Hole	16	11.50	34.5	\$211.73
1645571-001	DCC1645571	Poly/Cellulose	Open/Open	16	11.50	22	\$163.47
1658301-001	DCC1658301	Poly/Cellulose FR	Open/Open	13.8	9.48	28	\$165.61
1740802-001	DCC1740802	Spun Bond	Open/Open	13.8	9.48	28	\$219.30
1830603-001	DCC1830603	Poly/Cellulose	Open/Open	13.8	9.48	28	\$154.73
1835271-005	DCC1835271-5	Poly/Cellulose	Open/Closed with Bolt Hole	12.75	8.38	26	\$85.69
1835271-006	DCC1835271-6	Poly/Cellulose FR	Open/Closed with Bolt Hole	12.75	8.38	26	\$140.49
1835669-001	DCC1835669	Poly/Cellulose	Open/Open	12.75	8.38	26	\$132.56
Aercology							
7036-01	DCC7036-01	Poly/Cellulose FR	Open/Closed	13.8	9.48	18	\$136.00
7036-11	DCC7036-11	Poly/Cellulose FR	Open/Open	12.75	8.38	26	\$139.42
P191695	DCC191695	Poly/Cellulose	Open/Closed	13.8	9.48	18	\$136.00
P191695	DCC191695	Poly/Cellulose FR	Open/Open	13.8	9.48	26	\$147.96
P199472	DCC199472	Poly/Cellulose FR	Open/Open	13.8	9.48	26	\$155.12
Airex							
P432-26	DCC432-26	Cellulose	Open/Closed (Flange 14.25 x 16.00)	12.75	8.38	26	\$133.33
P432-36	DCC432-36	Poly/Cellulose	Open/Closed (Flange 14.25 x 16.00)	12.75	8.38	36	\$190.42
Airflow Systems							
7FRO2016	DCC7FRO2016	Call	Open/Closed	16	9.63	11.5	Call
7FRO2017	DCC7FRO2017	Call	Open/Closed	16	9.63	11.5	Call
7FRO2020	DCC7FRO2020	Call	Open/Closed	16	9.63	11.5	Call
7FRO2901	DCC7FRO2901	Call	Open/Closed	12.11	7.72	23	Call
7FRO2924	DCC7FRO2924	Call	Open/Closed	12.11	7.72	23	Call
Amerex							
114P	DCC114P	Cellulose	Open/Closed (Farr Style Flange)	12.75	8.38	26	\$133.33
AQE							
41114	DCC41114	Cellulose	Open/Open	12.75	8.38	30	\$139.58
41115	DCC41115	Poly/Cellulose FR	Open/Open	12.75	8.38	30	\$148.93
41116	DCC41116	Poly/Cellulose FR	Open/Open	12.75	8.38	30	\$171.47
41167	DCC41167	Spun Bond	Open/Closed	12.75	8.38	22	\$195.09
Baldwin							
PA2799	DCCPA2799	Poly/Cellulose	Open/Open	12.75	8.38	26	\$132.56
PA2856	DCCPA2856	Poly/Cellulose	Open/Closed with Bolt Hole	7.925	3.61	16	\$72.56
PA2857	DCCPA2857	Poly/Cellulose S	Open/Closed with Bolt Hole	12.75	8.38	26	\$153.85
PA2988	DCCPA2988	Cellulose	Open/Closed (Flange 14.25 x 16.00)	12.75	8.38	26	\$133.33

OEM Model No.	CLS Part #	Media Type	Description	OD"	ID"	Length"	List Price
BCP							
C30906	DCC30906	Cellulose	Open/Closed with Bolt Hole	12.75	8.38	36	\$129.02
C57612	DCC57612	Cellulose	Round Flange	14.25	8.38	36	\$175.43
Blastec							
206396-001	DCC206396	Poly/Cellulose	Open/Closed (Flange 14.25 x 16.00)	12.75	8.38	34	\$163.76
Blast-it-All							
OO6870	DCCOO6870	Poly/Cellulose	Open/Closed 14.25 Rnd Flange UTF	14.25	8.38	36	\$185.74
4010468	DCC4010468	Spun Bond	Open/Open	12.75	8.38	26	\$211.15
Clark							
1212201	DCC1212201	Poly/Cellulose	Open/Closed with Bolt Hole	12.75	8.38	26	\$138.70
1212203	DCC1212203	Poly/Cellulose FR	Open/Closed with Bolt Hole	12.75	8.38	26	\$140.49
1212232	DCC1212232	Poly/Cellulose FR	Open/Open	12.75	8.38	26	\$137.67
1212284	DCC1212284	Poly/Cellulose FR	Open/Closed (Flange 14.25 x 16.00)	12.75	8.38	26	\$155.37
1212287	DCC1212287	Poly/Cellulose	Open/Closed with Bolt Hole	7.925	3.61	16	\$72.56
1212292	DCC1212292	Poly/Cellulose	Open/Open	13.8	9.48	26	\$147.96
1212293	DCC1212293	Poly/Cellulose FR	Open/Open	13.8	9.48	26	\$155.12
1212294	DCC1212294	Poly/Cellulose	Open/Open	12.75	8.38	26	\$132.56
1212296	DCC1212296	Poly/Cellulose FR	Open/Open	13.8	9.48	22	\$148.91
1212727	DCC1212727	Poly/Cellulose S	Open/Closed with Bolt Hole 3 Bands	12.75	8.38	26	\$153.85
1565932	DCC1565932	Poly/Cellulose	Open/Closed 14.25 Rnd Flange UTF	14.25	8.38	36	\$185.74
Clean Air America							
1834	DCC1834	Poly/Cellulose FR	Open/Open	12.75	8.38	26	\$144.15
2468	DCC2468	Poly/Cellulose	Open/Open	12.75	8.38	26	\$132.56
Clemco							
15673	DCC15673	Cellulose	Open/Closed 14.25 Rnd Flange UTF	14.25	8.38	26	\$150.27
15781	DCC15781	Poly/Cellulose	Open/Closed 14.25 Rnd Flange UTF	14.25	8.38	36	\$185.74
Dollinger							
CY2212	DCCY2212	Cellulose	Open/Closed with Bolt Hole	12.75	8.38	22	\$122.62
CY2611P	DCCY2611P	Poly/Cellulose	Open/Closed with Bolt Hole	12.75	8.38	26	\$138.70
CY2612	DCCY2612	Cellulose	Open/Closed with Bolt Hole	12.75	8.38	26	\$121.38
Empire Filter							
515522	DCC515522	Poly/Cellulose	Open/Open	13.8	9.48	27	\$152.33
515525	DCC515525	Poly/Cellulose	Open/Closed with Bolt Hole	12.75	8.38	26	\$138.70
Endustra							
51013	DCC51013	Poly/Cellulose	Open/Closed 14.25 Rnd Flange UTF	12.75	8.38	22	\$138.97
51014	DCC51014	Cellulose	Open/Closed 14.25 Rnd Flange UTF	12.75	8.38	26	\$133.33
51050	DCC51050	Poly/Cellulose	Open/Closed with Bolt Hole	12.75	8.38	26	\$138.70
51053	DCC51053	Poly/Cellulose	Open/Open	12.75	8.38	26	\$132.56
51055	DCC51055	Cellulose	Open/Closed with Bolt Hole	12.75	8.38	26	\$121.38
51056	DCC51056	Poly/Cellulose	Open/Closed with Bolt Hole	7.925	3.61	16	\$72.56

OEM Model No.	CLS Part #	Media Type	Description	OD"	ID"	Length"	List Price
EnviroSystems							
60-01-001	DCC6001001	Cellulose	Open/Closed with Bolt Hole	12.75	8.38	26	\$121.38
60-01-005	DCC6001005	Poly/Cellulose FR	Open/Closed with Bolt Hole	12.75	8.40	26	\$140.49
60-01-006	DCC6001006	Poly/Cellulose FR	Open/Open	12.75	8.38	26	\$137.67
60-01-013	DCC6001013	Poly/Cellulose FR	Open/Closed with Bolt Hole	12.75	8.38	26	\$140.49
60-01-014	DCC6001014	Poly/Cellulose FR	Open/Open	12.75	8.38	26	\$137.67
60-01-019	DCC6001019	Poly/Cellulose	Open/Closed with Bolt Hole	12.75	8.38	26	\$138.70
60-01-020	DCC6001020	Poly/Cellulose S	Open/Closed with Bolt Hole	12.75	8.38	26	\$153.85
Farr							
202800-001	DCC202800	Poly/Cellulose	Open/Closed with Bolt Hole	12.75	8.38	26	\$138.70
084378-000	DCC084378	Poly/Cellulose	Open/Closed (Flange 14.25 x 16.00)	12.75	8.38	22	\$138.97
072518-004	DCC072518-4	Poly/Cellulose FR	Open/Closed (Flange 14.25 x 16.00)	12.75	8.38	26	\$155.37
078968-000	DCC078968-0	Poly/Cellulose	Open/Closed with Bolt Hole	12.75	8.38	26	\$138.70
079203-00	DCC079203	Poly/Cellulose	Open/Open	12.75	8.38	26	\$132.56
101400-004	DCC101400-4	Poly/Cellulose	Open/Closed (Flange 14.25 x 16.00)	12.75	8.38	34	\$163.76
121884-001	DCC121884-1SB	Spun Bond	Open/Closed (Flange 14.25 x 16.00)	12.75	8.38	26	\$164.17
121884-003	DCC121884-3SB	Spun Bond	Open/Closed (Flange 14.25 x 16.00)	12.75	8.38	34	\$211.07
125154-001	DCC125154-1	Cellulose	Open/Closed (Flange 14.25 x 16.00)	12.75	8.38	34	\$149.71
125154-002	DCC125154-2	Poly/Cellulose	Open/Closed (Flange 14.25 x 16.00)	12.75	8.38	34	\$163.76
125154-009	DCC125154-9	Cellulose	Open/Closed (Flange 14.25 x 16.00)	12.75	8.38	26	\$133.33
125154-013	DCC125154-13	Cellulose	Open/Closed (Flange 14.25 x 16.00)	12.75	8.38	26	\$133.33
Guyson							
500168	DCC500168	Poly/Cellulose FR	Open/Closed with Bolt Hole (Wrap)	12.75	8.38	26	\$160.01
500170	DCC500170	Poly/Cellulose	Round Flange	14.25	8.38	26	\$178.35
Hoffman/Torit							
8PP-44562-00	DCC44562	Poly/Cellulose	Open/Open	13.8	9.48	25.25	\$147.91
P190863-016-002	DCC190863	Cellulose	Round Flange/G SK/UTF	14.25	8.38	26	\$150.27
Ingersol Rand							
36853992	DCC36853992	Poly/Cellulose	Open/Open	13.8	9.48	27	\$152.33
36858405	DCC36858405	Cellulose	Open/Open	13.8	9.48	27	\$135.13
Mac-Mactiflo							
62101	DCC62101	Poly/Cellulose	Open/Open	13.8	9.48	30	\$157.30
321233	DCC321233	Poly/Cellulose	Open/Open	13.8	9.48	26	\$147.96
321236	DCC321236	Poly/Cellulose FR	Open/Open	13.8	9.48	26	\$155.12
321865	DCC321865	Poly/Cellulose FR	Open/Open	13.8	9.48	26	\$155.12
376094	DCC376094	Poly/Cellulose	Open/Open	13.8	9.48	30	\$157.30
376205	DCC376205	Poly/Cellulose	Open/Open	13.8	9.48	30	\$124.89
376213	DCC376213	Poly/Cellulose FR	Open/Open	13.8	9.48	30	\$184.21
376230	DCC376230	Spun Bond	Open/Open	13.8	9.48	30	\$270.65
McNelius Filter							
1140644	DCC1140644	Poly/Cellulose	Open/Closed with Bolt Hole	12.75	8.38	27	\$141.53

OEM Model No.	CLS Part #	Media Type	Description	OD"	ID"	Length"	List Price
Messer AG Filter							
P199407-461-002	DCC199407	Poly/Cellulose	Open/Open	13.8	9.48	27	\$152.33
Micro-Air Filter							
P3086	DCCP3086 *	Poly/Cellulose FR	Open/Closed with Bolt Hole (2 D Rings)	14.68	10.24	30	\$166.82
P3244	DCCP3244	Poly/Cellulose FR	Open/Closed with Bolt Hole (2 D Rings)	14.68	10.24	30	\$166.64
P3752	DCCP3752	Poly/Cellulose FR	Open/Closed with Bolt Hole (2 D Rings)	14.68	10.24	30	\$192.42
P7400RM	* DCCP7400RM	Poly/Cellulose FR	Open/Closed with Bolt Hole (2 D Rings)	14.68	10.24	30	\$171.23
P7402RM	DCCP7402RM	Poly/Cellulose FR	Open/Closed with Bolt Hole (2 D Rings)	12.75	8.38	16	\$124.99
Nordson							
101413	DCC101413	Poly/Cellulose	Open/Open	12.75	8.38	26	\$125.89
101414	DCC101414	Poly/Cellulose	Open/Closed	12.75	8.38	26	\$134.10
101429	DCP101429	Poly/Cellulose	Panel	14.13	24.00	2.25	\$63.79
101430	DCP101430	Poly/Cellulose	Panel	24	24.00	2.25	\$81.96
101431	DCP101431	Poly/Cellulose	Panel	24	20.00	2.25	\$69.22
101432	DCP101432	Poly/Cellulose	Panel	24	18.00	2.25	\$57.49
146416B	DCC146416B	Spun Bond	Open/Closed/Bands	12.75	8.38	26	\$129.77
146417B	DCC146417B	Spun Bond	Tri-Bolt	12.75	8.38	26	\$230.21
146418B	DCC146418B	Spun Bond	Open/Open	12.75	8.38	26	\$196.73
146419B	DCC146419B	Spun Bond	Open/Closed with Bolt Hole	12.75	8.38	26	\$199.16
147160B	DCC147160B	Poly/Cellulose	Open/Closed with Bolt Hole	12.75	8.38	26	\$127.87
147161B	DCC147161B	Poly/Cellulose	Tri-Bolt	12.859	8.37	26	\$160.79
147162B	DCC147162B	Poly/Cellulose	Open/Open	12.75	8.38	26	\$125.89
147163B	DCC147163B	Poly/Cellulose M	Open/Closed	12.75	8.38	26	\$89.31
147167B	DCC147167B	Poly/Cellulose	Tri-Bolt	12.859	8.37	26	\$160.79
151085B	DCC151085B	Spun Bond	Open/Open	12.75	8.38	36	\$237.04
151086B	DCC151086B	Spun Bond	Open/Closed	12.75	8.38	36	\$238.27
153129B	DCC153129B	Poly/Cellulose	Open/Open	12.75	8.38	36	\$147.95
153134B	DCC153134B	Poly/Cellulose M	Open/Closed	12.75	8.38	36	\$154.36
156995A	DCP156995A	Poly/Cellulose S	Final Panel	24	20.00	12	\$90.16
156996B	DCC156996B	Spun Bond	Open/Closed with Inner Nut	12.75	8.38	36	\$219.23
156998B	DCC156998B	Poly/Cellulose M	Open/Closed with Inner Nut	12.75	8.38	36	\$156.23
180770B	DCC180770B	Poly/Cellulose	Open/Open	12.75	8.38	36	\$146.48
180771B	DCC180771B	Poly/Cellulose	Open/Closed	12.75	8.38	36	\$147.50
180775B	DCC180775B	Poly/Cellulose	Open/Closed with Inner Nut	12.75	8.38	32	\$183.23
1014921	DCC1014921	Spun Bond	Open/Closed with Bolt Hole	12.75	8.38	36	\$261.33
1042591	DCC1042591	Spun Bond	Dimpled Spunbond	12.75	8.38	48	\$507.02

OEM Model No.	CLS Part #	Media Type	Description	OD"	ID"	Length"	List Price
Pangborn							
P880069	DCCP880069	Cellulose	Open/Closed with Bolt Hole	12.75	8.38	26	\$121.38
P9600281	DCCP9600281	Poly/Cellulose FR	Open/Closed with Bolt Hole	12.75	8.38	26	\$140.49
P9600356	DCCP9600356	Poly/Cellulose	Open/Open	13.8	9.48	26	\$147.96
P960357	DCCP960357	Poly/Cellulose	Open/Open	12.75	8.38	26	\$132.56
P960358	DCCP960358	Poly/Cellulose	Open/Open	13.8	9.48	26	\$147.96
Plymovent							
6815-1001	DCC6815-1001	Spun Bond	Open/Closed with Bolt Hole	12.75	8.38	29.125	\$307.87
6815-1011	DCC6815-1011	Poly/Cellulose	Open/Closed with Bolt Hole	12.75	8.38	29.125	\$137.10
6815-1011FR	DCC6815-1011FR	Poly/Cellulose FR	Open/Closed with Bolt Hole	12.75	8.38	29.125	\$139.70
Steelcraft							
970-1	DCC970-1	Cellulose	Open/Closed with Bolt Hole	12.75	8.38	29	\$95.16
970-2	DCC970-2	Cellulose	Open/Closed with Bolt Hole/Bands	12.75	8.38	29	\$95.16
970-3	DCC970-3	Poly/Cellulose	Open/Closed with Bolt Hole	12.75	8.38	29	\$99.05
970-4	DCC970-4	Poly/Cellulose	Open/Closed with Bolt Hole/Bands	12.75	8.38	29	\$99.05
971-1	DCC971-1	Cellulose	Open/Open	12.75	8.38	29	\$92.75
971-2	DCC971-2	Cellulose	Open/Open/Bands	12.75	8.38	29	\$92.75
971-3	DCC971-3	Poly/Cellulose	Open/Open	12.75	8.38	29	\$92.75
971-4	DCC971-4	Poly/Cellulose	Open/Open/Bands	12.75	8.38	29	\$94.97
Torrit/Donaldson							
8PP-18803-00	DCC18803	Poly/Cellulose	Open/Closed with Bolt Hole	7.925	3.61	16	\$46.52
8PP19215-00	DCC19215	Cellulose	Open/Closed with Bolt Hole	12.75	8.38	26	\$79.50
8PP-19230-00	DCC19230	Poly/Cellulose	Open/Closed with Bolt Hole	12.75	8.38	26	\$138.70
8PP-19524-00	DCC19524	Poly/Cellulose	Open/Closed with Bolt Hole	12.75	8.38	26	\$138.70
8PP-19600-00	DCC19600	Poly/Cellulose FR	Open/Closed with Bolt Hole	12.75	8.38	26	\$85.86
8PP-19624-00	DCC19624	Poly/Cellulose S	Open/Closed with Bolt Hole	7.925	3.61	16	\$72.79
8PP-20112-00	DCC20112	Poly/Cellulose FR	Open/Closed with Bolt Hole	7.925	3.61	16	\$48.21
8PP-20246-00	DCC20246	Poly/Cellulose S	Open/Closed with Bolt Hole	7.925	3.61	16	\$72.79
8PP-20247-00	DCC20247	Poly/Cellulose	Open/Closed with Bolt Hole	12.75	8.38	26	\$85.70
8PP-21028-00	DCC21028	Poly/Cellulose	Open/Closed with Bolt Hole	12.75	8.38	26	\$85.70
8PP-21347-00	DCC21347	Poly/Cellulose	Open/Closed with Bolt Hole	12.75	8.38	26	\$85.70
8PP-21586-00	DCC21586	Poly/Cellulose	Open/Closed with Bolt Hole	7.925	3.61	16	\$46.52
8PP-22269-00	DCC22269	Poly/Cellulose	Open/Open	12.75	8.38	26	\$83.92
8PP-22839-00	DCC22839	Poly/Cellulose	Open/Closed with Bolt Hole	7.925	3.61	16	\$46.52
8PP-22343-00	DCC22343	Poly/Cellulose	Open/Open	12.75	8.38	26	\$83.92
8PP-23099-00	DCC23099	Cellulose	Open/Open	12.75	8.38	26	\$79.50
8PP-24009-00	DCC24009	Poly/Cellulose FR	Open/Open	12.75	8.38	26	\$85.70
8PP-25116-00	DCC25116	Poly/Cellulose	Open/Closed with Bolt Hole	12.75	8.38	26	\$85.69
8PP-25118-00	DCC25118	Poly/Cellulose	Open/Open Conical	16	12.75	26	\$126.88
8PP-25370-00	DCC25370	Poly/Cellulose FR	Open/Open	13.8	9.48	22	\$93.39
8PP-27152-00	DCC27152	Poly/Cellulose FR	Open/Open/ no gasket	17.6	12.23	18	\$104.70

8PP-27488-00	DCC27488	Poly/Cellulose	Open/Closed with Bolt Hole	7.925	3.61	16	\$46.52
OEM Model No.	CLS Part #	Media Type	Description	OD"	ID"	Length"	List Price
8PP-32531-00	DCC32531	Cellulose	Open/Open	13.8	9.48	26	\$130.50
8PP-32535-00	DCC32535	Poly/Cellulose	Open/Open	13.8	9.48	26	\$147.96
8PP-32537-00	DCC32537	Cellulose	Open/Open	13.8	9.48	26	\$130.50
8PP-32582-00	DCC32582	Poly/Cellulose	Open/Closed (Flange 14.25 x 16.00)	12.75	8.38	26	\$167.79
8PP-40764-00	DCC40764	Poly/Cellulose FR	Open/Closed with Bolt Hole	12.75	8.38	26	\$141.60
8PP-40765-00	DCC40765	Poly/Cellulose FR	Open/Closed with Bolt Hole	7.925	3.61	16	\$74.92
8PP-40766-00	DCC40766	Poly/Cellulose FR	Open/Open	12.75	8.38	26	\$139.42
8PP-40767-00	DCC40767	Poly/Cellulose FR	Open/Open Conical	16	12.75	26	\$203.78
8PP-41546-00	DCC41546	Poly/Cellulose	Open/Open	12.75	8.38	26	\$132.56
8PP-40214-00	DCC40214	Poly/Cellulose	Open/Closed with Bolt Hole	12.75	8.38	26	\$138.70
8PP-42057-00	DCC42057	Poly/Cellulose	Open/Open	13.8	9.48	26	\$147.96
8PP-42058-00	DCC42058	Poly/Cellulose FR	Open/Open/	13.8	9.48	26	\$155.12
8PP-42360-00	DCC42360	Poly/Cellulose S	Open/Open/Bands	12.75	8.38	26	\$150.95
8PP-42361-00	DCC42361	Poly/Cellulose S	Open/Closed with Bolt Hole/Bands	12.75	8.38	26	\$153.85
8PP-44103-00	DCC44103	Poly/Cellulose S	Open/Open/Bands	13.8	9.48	26	\$162.72
8PP-46546-00	DCC46546	Poly/Cellulose FR	Open/Closed with Bolt Hole/Flanged	9.21	4.83	22.3	\$119.19
8PP-46638-00	DCC46638	Poly/Cellulose	Open/Closed with Bolt Hole/Flanged	9.21	4.83	22.3	\$115.15
8PP-46774-00	DCC46774	Poly/Cellulose S	Open/Open/Bands	12.75	8.38	26	\$150.95
8PP-47400-00	DCC47400	Poly/Cellulose S	Open/Open/Bands	13.8	9.48	26	\$162.72
8PP-47402-00	DCC47402	Poly/Cellulose S	Open/Closed with Bolt Hole/Bands	12.75	8.38	26	\$153.85
8PP-48001-00	DCC48001	Poly/Cellulose FR	Open/Open/	13.8	9.48	26	\$155.12
8PP-48260-00	DCC48260	Poly/Cellulose	Open/Closed with Bolt Hole	12.75	8.38	26	\$138.70
8PP-72457-01	DCC72457	Poly/Cellulose FR	Open/Closed with Bolt Hole	12.75	8.38	26	\$140.49
8PP-72458-01	DCC72458	Poly/Cellulose FR	Open/Closed with Bolt Hole	7.925	3.61	16	\$74.92
8PP-72463-01	DCC72463	Poly/Cellulose	Open/Closed with Bolt Hole	7.925	3.61	16	\$72.56
8PP-72476-01	DCC72476	Poly/Cellulose	Open/Open	13.8	9.48	26	\$147.96
8PP-72477-01	DCC72477	Poly/Cellulose	Open/Open	12.75	8.38	26	\$132.56
8PP-72478-01	DCC72478	Poly/Cellulose	Open/Closed with Bolt Hole	12.75	8.38	26	\$138.70
8PP-72479-01	DCC72479	Poly/Cellulose	Open/Closed with Bolt Hole	7.925	3.61	16	\$72.56
8PP-72481-01	DCC72481	Poly/Cellulose FR	Open/Open	13.8	9.48	26	\$155.12
P031388	DCC031388	Cellulose	Open/Closed with Bolt Hole	13.8	9.48	26	\$126.76
P145891-016-436	DCC145891	Poly/Cellulose	Open/Closed with Bolt Hole	12.75	8.38	26	\$138.70
P148646-016-436	DCC148646	Poly/Cellulose	Open/Closed with Bolt Hole	7.925	3.61	16	\$72.56
P151244-016-436	DCC151244	Poly/Cellulose	Open/Open	12.75	8.38	26	\$132.56
P190805-016-436	DCC190805	Poly/Cellulose	Open/Open	12.75	8.38	26	\$132.56
P190817-016-436	DCC190817	Poly/Cellulose	Open/Open	13.8	9.48	26	\$147.96
P190818-016-436	DCC190818	Poly/Cellulose FR	Open/Open	13.8	9.48	26	\$155.12
P190899-016-436	DCC190899	Poly/Cellulose	Open/Open	13.8	9.48	26	\$147.96
P190906-016-436	DCC190906	Poly/Cellulose	Open/Open	13.8	9.48	26	\$147.96

P191115-461-340	DCC191115	Poly/Cellulose FR	Open/Closed with Bolt Hole/Flanged	9.21	4.83	22.3	\$119.19
P191116-460-340	DCC191116	Poly/Cellulose	Open/Closed with Bolt Hole/Flanged	9.21	4.83	22.3	\$115.15
OEM Model No.	CLS Part #	Media Type	Description	OD"	ID"	Length"	List Price
P191233-016-436	DCC191233	Poly/Cellulose	Open/Closed with Bolt Hole	12.75	8.38	26	\$138.70
P191521-016-436	DCC191521	Poly/Cellulose FR	Open/Open/Bands	13.8	9.48	26	\$146.37
P191522-016-436	DCC191522	Poly/Cellulose FR	Open/Open	12.75	8.38	26	\$139.42
P191523-016-436	DCC191523	Poly/Cellulose FR	Open/Closed with Bolt Hole	12.75	8.38	26	\$141.60
P191524-016-436	DCC191524	Poly/Cellulose FR	Open/Closed with Bolt Hole	7.925	3.61	16	\$74.92
P191526-016-436	DCC191526	Poly/Cellulose	Open/Open/2Bands	13.8	9.48	26	\$139.79
P191889-461-436	DCC191889	Poly/Cellulose/NANO	Open/Open DFO	14.4	11.40	26	\$141.34
P191920-461-436	DCC191920	Poly/Cellulose/NANO-FR	Open/Open DFO	14.4	11.40	26	\$170.40
P199413-016-431	DCC199413	Poly/Cellulose S	Open/Open DFO	14.4	11.40	26	\$204.05
P199474-016-436	DCC199474	Spun Bond HO	Open/Open DFO	14.4	11.40	26	\$146.39
P520444-016-340	DCC520444	Poly/Cellulose	Open/Open/Conical	16	12.75	26	\$194.08
P522193-460-340	DCC522193	Poly/Cellulose FR	Open/Open	13.8	9.48	22	\$148.91
P522963-461-340	DCC522963	Poly/Cellulose FR	Open/Open/ no gasket	17.6	12.23	18	\$162.01
P526591-016-340	DCC526591	Poly/Cellulose	Open/Closed with Bolt Hole	12.75	8.38	26	\$138.70
P527078-461-436	DCC527078	Poly/Cellulose FR	Open/Open	12.75	8.38	26	\$137.67
P527080-461-436	DCC527080	Poly/Cellulose FR	Open/Closed with Bolt Hole	12.75	8.38	26	\$141.60
P527081-016-340	DCC527081	Poly/Cellulose FR	Open/Open/Conical	16	12.75	26	\$203.78
UAS/Dust Hog							
33-0226	DCC0226	Poly/Cellulose	Open/Closed with Bolt Hole	7.925	3.61	16	\$72.56
33-0290	DCC0290	Poly/Cellulose FR	Open/Open	12.75	8.38	26	\$137.67
33-0291	DCC0291	Poly/Cellulose FR	Open/Open	12.75	8.38	30	\$162.97
33-0320	DCC0320	Poly/Cellulose	Open/Open	12.75	8.38	26	\$132.56
33-0324	DCC0324	Poly/Cellulose FR	Open/Closed with Bolt Hole	12.75	8.38	26	\$141.60
Wagner Booth							
FIL-1060	DCC1060	Poly/Cellulose	Open/Open	12.75	8.38	26	\$131.58
Wheelabrator							
621380	DCC621380	Cellulose	Open/Closed (16.50 x 15.00 Flange)	12.75	8.38	36	\$150.98
661394	DCC661394	Cellulose	Round Flange	14.25	8.38	26	\$97.52
681696	DCC681696	Poly/Cellulose	Open/Closed with Bolt Hole	7.925	3.61	32	\$95.32
803600882	DCC803600882	Poly/Cellulose	Round Flange/Gsk/Top	14.25	8.38	36	\$154.69
833600882	DCC833600882	Cellulose	Open/Closed (16.50 x 15.00 Flange)	12.75	8.38	36	\$150.98

Air Filtration Engines, Compressors & Blowers

Intake Air applications for Stationary Engines, Gas Turbines, compressors and blowers. Several types of media can be used in the design of the intake air filter for your specific application. Impregnated Cellulose is used when moisture resistance is critical. Low energy media with acrylic resin/cellulose or PVA/Cellulose can be used in protective environments. Spun bonded, self supporting and wire backed polyester, along with microglass media are also available.

- Cartridge filter
- Inlet filters Panel style
- Marine Applications



**Engine Intake Housings
in Carbon Steel or
Stainless Steel**
**1" NPT up to 60"
Flange Connection**



The Panel style XL is an exceptional high efficiency filter utilizing a glass fiber woven media. It is designed for use as the final filter stage in machinery intake systems where rigid construction and long service life are essential. Panel XL filters operate at air volumes up to 2500 cfm and are capable of withstanding temperatures up to 302°F (248°F continuously). Model XL60 & XL90 measure 24" x 24" x 12" (nominal) with an initial resistance of 0.45" w.g. @ 2000 cfm. Rated 70% average dust spot efficiency. Maximum dust holding capacity over 1400grams



Panel style intake filters used as prefilters and sometimes used as the main filter on small engine to mid size engine & compressor

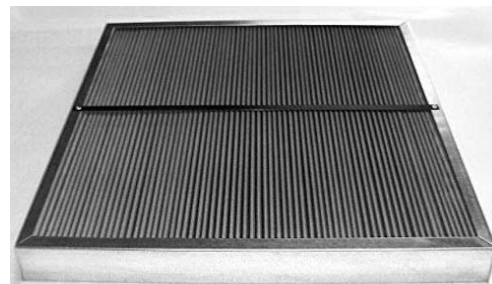

Air Filtration Housings | Engine and Compressor Intake

Air Intake from 10 CFM to 40,000 CFM Cylindrical Or Panel Style design

Single stage to 5 stage filtration

Wire Mesh to HEPA grade filters

Available with gas/molecular filtration



Oil Separators / Air-Oil Separators

Compressed air and gas is essential in many industries for its use in equipment operation, instrumentation, refrigeration and a variety of industrial processes. Clean, oil-free air or gas is a requirement to reduce maintenance costs. Even atmospheric air contains objectionable contaminants, in both solid and liquid forms, that must be removed prior to the use of compressed gas. Additionally, in many compressor and vacuum packages, oil is intentionally introduced as a coolant and sealant which must also be taken out prior to air use. We offer a wide range of air-oil separators for air compressors and vacuum packages, as well as air inlet, oil and coalescing type filters, that when used together, provide essential system operation and protection. CLS oil separators operate on the familiar principles of fine liquid droplet coalescence in a flowing gas stream. These processes have been refined into packages that meet the special high performance and physical requirements of the air/gas compressor industry. Regardless of style (conventional, pleated or deep), our oil separators will provide for performance as shown here:

Pressure drop (at load): 2-3 psi / .20 bar

Pressure resistance (against collapse): 70 psi / 5.0 bar

Efficiency (remaining oil in gas stream): 2-3 ppm / 2-3 mg/m³

Operating temperature: (standard) 180° F / 82° C to 230° F / 110° C (Higher temperature models available)

Materials: A. Media—both wet laid and high loft solely or in combination

B. Bonding compound—polyurethane or epoxy

C. Body components—corrosion resistant steel

Service life: Dependent mainly upon the cleanliness of the oil and gas being compressed as well as the initial amount of oil contained in the gas stream; several thousands of hours of operation are possible in a well-functioning compressor or vacuum system.



Air Filtration HVAC (Heating, Ventilation and Air Conditioning)

HEPA Filters, 95%DOP, 98%DOP, 99.97%, 99.99%, 99.999% at 0.3 micron

ULPA rated at 0.12 micron

4V filters rated for up to 2000 CFM at 1.2" w.g.

5V and 6V Super High Capacity HEPA filters up to 2400 CFM at 1" w.g.

HEPA HV filters are manufactured from continuous length superior quality micro glass fiber paper media available in various efficiencies from H13 - H14. The filter media is moisture resistant and fire retardant. Anti-microbial treated papers are also available for special applications. The uniform and closed pleat filter pack grants a high crossing surface to hold the very fine dusts.



4V operates at very high air velocity up to 2000 CFM if required delivering a very low pressure drop. The V shaped arrangement allows more air flow per filter wherein a standard filter replacement can save up to 30% energy savings. Filters are light weight and its fully plastic body makes it incinerable as well.



Standard and High Capacity HEPA in metal or wood frames with Aluminum Separators up to 2000CFM

HEPA SC & HC filters are deep pleated aluminum separator filters with efficiencies ranging from 95%DOP to 99.97%, 99.99% and 99.999% at 0.3 micron and EN1822 grades E10 to H14. These filters are available in wood and metal construction. Box type or double turned flanged version available.

Filter Media

HEPA SC & HC filters are manufactured from continuous length high quality micro glass fiber paper media available in various efficiency grades from E10 to H14. The filter media is moisture resistant and fire retardant. Anti-microbial treated papers are also available for special applications. The uniform and closed pleat filter pack provides a high crossing surface to hold the very fine dusts



Filter Frames

The standard frame construction includes fire retardant Wood Particle board, galvanized steel (16,18 or 24gauge) or anodized aluminum. High temperature versions are constructed with Stainless steel frames

Sealant & Gaskets

The pleated media pack is encapsulated into the filter frame utilizing a urethane elastomer. A flat profile neoprene gasket or a one-piece seamless urethane gasket is used to ensure a leak free seal to the filter housing. High temperature versions are manufactured with ceramic sealant and temperature resistant gasket.

Media Separators

In our HEPA SC & HC filters, the pleated media is evenly and accurately positioned by corrugated aluminum separators having hemmed edges to add strength and to protect the media pack.

Filter Testing

The finished filter undergoes a thorough quality check. They are scan tested individually to ensure a leak proof performance and each filter has a label showing the scan test result on it. We have testing facilities as per EN779 : 1822 Standard.

HEPA SC	Rated Airflow @ 1" WG (CMH)			HEPA HC	Rated Airflow @ 1" WG (CMH)		
	Filter Size (mm)	H12	H13		H14	Filter Size (mm)	H12
Size: 305 x 610 x 150	540	540	442	Size: 305 x 610 x 150	725	725	610
Size: 610 x 610 x 150	1140	1140	935	Size: 610 x 610 x 150	1530	1530	1275
Size: 305 x 610 x 292	970	970	935	Size: 305 x 610 x 292	1370	1370	1130
Size: 610 x 610 x 292	2040	2040	1700	Size: 610 x 610 x 292	2890	2890	2380

High-Temperature applications with Alum separators in deep pleat box style filters.
Filters are available from MERV 12, MERV14 and HEPA range.
Filters are silicone free and can withstand up to 725°F/ 385°C
**HEPA Max 500°F



V- Cells | Available in Glass and Synthetic media

ASHRAE 52.2 Efficiencies from MERV 12 to MERV 16 Plus DOP and HEPA rated V-cells

EN779 Rated M6, F7, F8, F9

EN1822 Rated E10, E11, E12, H13, H14

All plastic frame with 20 or 25mm Headers 12", 16" or 17" depth

Plastic Blow out grids to withstand up to 25" W.G.

V-Cells are designed to use in HVAC installations where highest degree of air cleanliness is required.

The compact design, larger surface area and low initial resistance made it an Ideal alternative to ordinary Bag filters & Box type filters of the similar efficiencies.



Rigid Cells | Synthetic or Glass Media

MERV Rated MERV 11 to MERV 15 available in BOX or Header style for Variable Air Volume Systems in 4", 6" and 12" depths. Medium to high efficiency extended surface deep pleated rigid box filters are manufactured from a new generation range of inherently anti-microbial, high lofted synthetic fiber filter media or micro - fine glass fiber filter media. It is capable of removing contaminants from the air stream and is an ideal fine filter for HVAC systems.



Pocket Filters | Bag Filters (Synthetic)

MERV 11, MERV 12, MERV 13, MERV 14, MERV 15 and MERV 16
EN779 Rated M6, F7, F8, F9

Medium to high efficiency extended surface bag filters are manufactured from a new generation range of inherently anti-microbial high lofted synthetic fiber filter media. S-BAG offers excellent filtration performance combined with high dust holding capacity and suitable for applications where highest degree of air cleanliness is required.



Pocket Filters | Bag Filters (Microglass)

MERV 12, MERV 13, MERV 14, MERV 15
EN779 Rated M5, M6, F7, F8

G-BAG provides extended surface filtration through media formed into individual dust holding pockets. These pockets are created by internal span stitches to maintain uniform airflow channels for even dust loading and long filter life. The perfectly balanced pocket design allows full pocket inflation without crowding or restricting airflow to ensure optimum media utilization and thereby offering long service life. Each pocket is bonded and sealed to its own “J” channel support frame which is fastened to a heavy duty corrosion resistant steel frame with soft edges to avoid damage to the filter media.



Stiff Pocket Filters | Bag Filters (Synthetic)

MERV 8, MERV 11, MERV 12, MERV 13, MERV 14, MERV 15
EN779 Rated G4, M5, M6, F7, F8

SPX-BAG filters are medium to high efficiency extended surface self-supporting Pocket (bag) filters made of super fine synthetic (Polyester) filter media. The progressive density multi-layered fiber arrangement offers excellent filtration performance combined with very high dust holding capacity. SPX bags are Ideal for air intake applications in Automotive paint booths, powder coating and other surface treatment plants. This is also used in air conditioning systems in Hospitals, Pharmaceutical plants, food processing plants, electronic manufacturing facilities etc. With a unique aerodynamic design, this is also available for air intake applications like gas turbines, diesel generators.

The rigid pockets are formed by welded construction and aerodynamic design. The pockets are mechanically fastened in an ABS frame. This construction ensures 100% leak proof operation. SPX-BAG Filters are completely metal free and are designed to withstand high burst pressure tested up to 25 inches water gauge. These filters can operate well in 100% humid conditions and in salt-laden environments.



Mini-Pleat Panel filters

are the new generation of high efficiency compact filters available in a wide range of efficiencies from MERV12 to MERV 14. These filters are designed for use in HVAC installations where highest degree of air cleanliness is required. The compact design, larger surface area and low initial resistance made it an ideal alternative to ordinary bag filters and box type filters of the similar efficiencies.

These filters are made up of water-resistant micro glass filter media, closely pleated and separated by continuous thermo-plastic bead separators. This design accommodates a very large quantity of media which offers a longer service life and low pressure drop. The Mini-Pleated media packs are encased in a metal or plastic frame that are available with single, double or no header style. Available from 1" to 6" depth.

Also available in 100% synthetic filter media made from a modified meltblown process having graded fiber density ensuring coarse fibers upstream and fine fibers downstream is closely pleated adding thermo-plastic bead separators which gives a unique V configuration to the pleats and accommodates a very large quantity of filter media. The low initial pressure drop, longer service life and the compact design made it an ideal design for all types of air conditioning installations. The filters are available in plastic or metal frames. The filter media used is inherently anti-microbial and so it inhibits the growth of micro-organisms.



High Temperature | Mini-Pleats

MPHT filters are designed for drying plants operating at high temperatures. This filter operates at 725°F /385°C , with lower pressure drop and longer service life. They replace the conventional deep pleat style filters in similar range. Maximum recommended pressure drop is 1.4" w.g. Available in 1.6", 2.17" and 3.08" depths and efficiencies MERV 12 and MERV 14. HEPA 99.99% grade available with a Max Temp of 500°F



HT pleat filters are designed as a pre filter operating at high temperatures up to 500°F/260° C, with low pressure drop and long service life. Filters are classified with MERV8/G4/EU4 efficiency. They are made with a pleat distribution of 13 pleats per linear foot and are recommended to operate up to 2000 CFM. These filters are available in 45mm (2") and 95mm (4") depths. Filter face area can be custom made in many dimensions and the maximum recommended pressure drop is 1.2" w.g./300 Pa.



Washable filters

Expanded Aluminum Foil Filter is an impingement type panel filter designed for use in residential, commercial and industrial HVAC applications to remove large airborne particulate. Popular applications include outside air intake ducts, rooftop hoods and air handling units. It is an ideal solution for any HVAC system that desires a washable and durable pre-filter with low resistance to airflow.



Screen Mesh available in Aluminum, Galvanized or Stainless Steel

Often used in high velocity applications, screen mesh industrial grade filters are an impingement type panel filter designed for use in residential, commercial and industrial HVAC as well as large electrical motor applications to remove large airborne particulate and mist from the airstream. Applications include outside air intake ducts, rooftop hoods and air handling units. It is an ideal solution for any HVAC system that desires a washable pre-filter with low resistance to airflow. The filter uses a metal frame to enclose the media pack consisting of multiple layers of corrugated screen wire assembled in a criss crossing pattern for strength. The pack is then placed between two layers of expanded metal and is made to fit firmly inside the frame giving the filter exceptional strength and durability. The frame is made with mitered corners and is closed with rivets. The frame has drain holes for ease in cleaning.



Paint Booth Filtration | Prefilter rolls

Fiberglass filter media rolls used in paint overspray collection and surface coating applications. Filter media is made up of glass fiber media. Typical thicknesses 2.5" are available in rolls and cut to length pads.

Various weights per square ft of glass fiber media provide different efficiency levels and greater dust holding capacity.



Ring Panels



Used in HVAC or Paint booth applications.

2 ply panels are used in paint booth cross draft applications where the user requires a good basic filter and cost is a major consideration. Typical 1.5" green, 2-ply, self-sealing, tackified polyester media. Panels are heat sealed around steel frame. Available in panels, pads, and blankets 83% efficient @ 5-10 micron range @ 100fpm

Extra tack panels for use in cross draft applications. An industry favorite, the Extra Tack is a long-life filter that is a proven performer at a great price. A standard 1.75" blue, 2-ply, self-sealing, tackified polyester media. Panels are heat sealed around steel frame. Available in panels, pads, and blankets

94% efficient @ 5-10 micron range @ 100fpm

- Air Intake
- Paint Overspray
- Downdraft Filters

Air Filtration Housings | Engine and Compressor Intake

Air Intake from 10 CFM to 40,000 CFM Cylindrical Or Panel Style design

Single stage to 5 stage filtration

Wire Mesh to HEPA grade filters



Process (In Line housings)



HVAC

Flat Bank Housing

The Flat Bank air filter housing is a permanent housing designed to hold ASHRAE rated air filters. Standard filter sizes are 2" or 4" in depth. Housings are manufactured in 8-½" and 12" depths. This housing is fabricated from galvanized steel or -optional T304 stainless steel and is welded together and or bolted together. The unit is one-piece construction with aluminum extrusion to hold the filters in place. Upstream corner gussets increase the rigidity of the unit. Each unit is manufactured to meet specific end user requirements.



The Side Access air filter housing is a permanent housing designed to specifically accommodate ASHRAE rated air filters. Filter efficiencies range anywhere from 30-95% by ASHRAE test method. This 22-¼, 34-¼, 42" or customized depth housing is manufactured with galvanized steel- optional T304 stainless steel and is intermittently welded and or bolted together. All seams are silicone caulked for airtight seal. The unit is a one-piece construction with filter track extrusion permitting either a 2", 4" or 6" prefilter track and a 1" final filter header track. Each housing is custom manufactured to meet specific end user requirements.

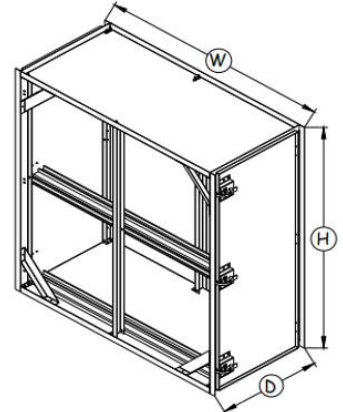

Aluminum Extrusion

Prefilter and secondary 1" header filter tracks are available with 2" and 4" prefilters.

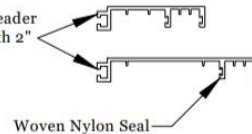

V Bank filter housing is a permanent single stage unit designed to hold pleated ASHRAE rated filters. The unit can accommodate both 2" and 4" filters in a low-pressure drop configuration. The V Bank unit is manufactured out of either galvanized steel or optional stainless steel and is welded and or bolted together. Each housing is custom manufactured to meet specific end user requirements

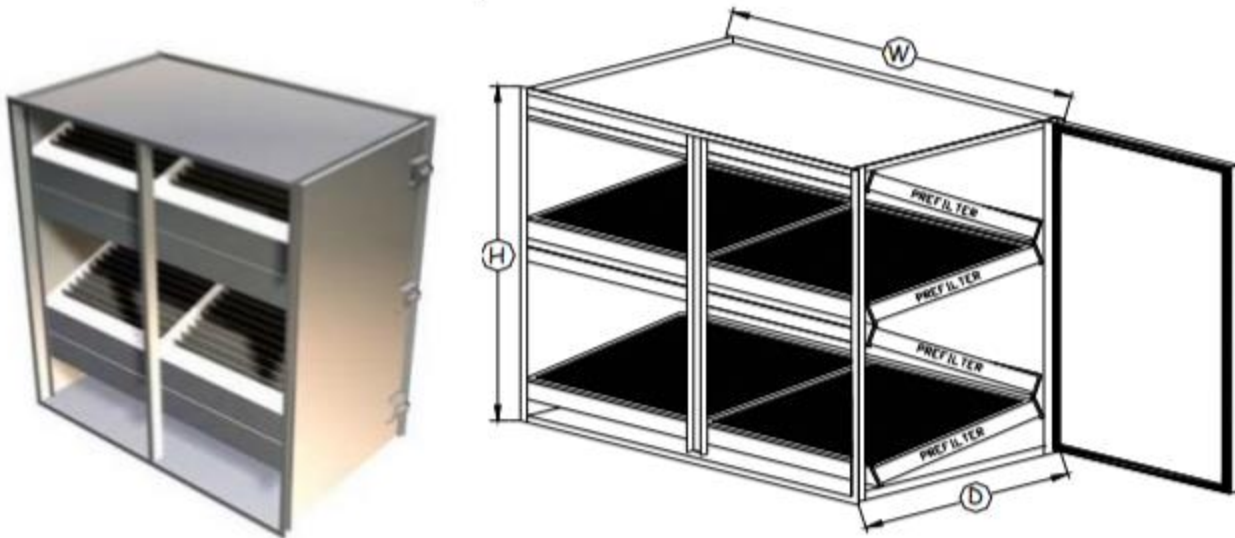

Carbon filter/adsorber housing is a permanent multi stage unit designed to remove particulate and gas phase molecular contaminants. The molecular contamination unit accommodates either a 2" or 4" deep prefilter section as well as nominal 3/4" carbon trays. Tray configuration is based on twelve trays per twenty-four inches of height. The air filter housing can accommodate multiple face style filters in a low-pressure drop. This Carbon housing is fabricated out of galvanized steel-optional stainless steel. Corner gussets are added to strengthen the structure of the housing. Shelves within the unit are bolted in place in order to accommodate varying manufacturers filters. Each housing is custom made to meet specific end user requirements.



BIBO (Bag in /Bag out) | Critical Containment Housings

Single Door Unit



Double Door Unit



Larger unit with isolation dampers



Custom filters | Designed to order

Custom HEPA filters



Custom High Pressure Stainless Steel mesh filters. Sintered powder, Sintered Mesh and Sintered fiber filters available





**Custom CAD cut shapes from High grade Disposable Polyester media.
Send us the design that fits your fan or equipment and we will make it.
50 pcs or 10,000 pcs.**



Replacements for most major Brands

Air Housings

- Ajax
- Caterpillar
- Clark
- Cooper Bessemer
- Ingersoll Rand
- MEP
- Moisture Master
- Solar Gas Turbine Systems (Saturn thru Titan)
- Solberg
- Waukesha-Pearce
- White Superior
- Worthington

Dust Collectors

Donaldson/Torit

- American Air
 - Braden
 - Camfil
 - Farr
 - FilterOne
 - Clean Air Consultants
 - Lincoln Electric
 - Nordson
 - Pneumafil
 - GEMA
 - MAC Equipment
 - Trion
 - Wheelabrator
- and many others

Liquid cartridges

- Amazon Filter
- Filtration Group
- GE
- Jonell
- Parker (Commercial)
- Pall
- Strainrite

Coalescers & Separators

- American Filter Tech
- Baldwin
- C&M Filtration
- Facet
- Guardian Labs
- HILCO
- Jonell (Filtration Group)
- Kaydon
- Murphy
- Pall
- Parker
- Peco
- Refilco
- Racor(Parker)
- Velcon (Parker)

- *AAF*
- *ACTION FILTRATION*
- *AERCOLOGY*
- *AIR KNIFE*
- *AIR MAZE*
- *AIR QUALITY ENGINEERING*
- *AIR REFINER*
- *AIR-RITE*
- *AIREX*
- *AIRGUARD*
- *AIRTROL*
- *AJAX*
- *ALTAIR*
- *AMEREX*
- *APEL*
- *AQE*
- *ATLAS COPCO*
- *BACT*
- *BALDWIN*
- *BCP (BLAST PRO)*
- *BEALE*
- *BHA*
- *BINKS*
- *BIO BLAST*
- *BLASTEC*
- *BLASTRAC*
- *BOWSER*
- *BRADEN*
- *BURGESS MANNING*
- *CAMFIL FARR*
- *CASCO*
- *CATERPILLAR*
- *CAVEL*
- *CHAMPION*
- *CHAMPION LABS*
- *CHEMCO*

- CLARK
- CLEAN AIR OF AMERICA
- CLEMCO
- COMMERCIAL
- COMPLETE
- CONAIR
- CONSLER
- COOPER AIR
- DEIMCO
- DIVERSIFIED ENGINE PRODUCTS
- DIVERSITECH
- DOLLINGER
- DONALDSON TORIT
- DSP MONOXIVENT
- DUST HOG
- DUSTEX
- EARTH FILTRATION
- ECO
- EMPIRE
- ENDUSTRA
- ENTECH APC
- ENVIRO-SYSTEMS
- ENVIRONMENTAL
- EXIJET
- FACET
- FALLS FILTRATION
- FARR
- FILMSCO
- FILTER CLONE
- FILTRATION GROUP
- FILTRATION SYSTEMS (FSI)
- FILTREX
- FISHER KLOSTERMANN
- FLANDERS
- FLEETGUARD
- FLEXKLEEN

- *FORCAST SALES*
- *FRAM*
- *FREUDENBERG*
- *FSX*
- *GARDNER DENVER*
- *GEMA*
- *GENERAL RESOURCE*
- *GORE*
- *GUYSON*
- *HILCO*
- *HOFFMAN BLAST ROOM*
- *HOFFMAN BLOWER*
- *IFM (INDUSTRIAL FILTER MFG)*
- *INGERSOLL RAND*
- *IONTECH*
- *IPEC*
- *JBI*
- *JET AIR*
- *JONELL*
- *KAYDON KEENE*
- *KEI*
- *KINGTOOL*
- *KOCH*
- *LUBER FINER*
- *MAC*
- *MAC TIFLOW*
- *MAKINO SINTO*
- *MCNELIUS*
- *METROPLEX*
- *MICRO AIR*
- *MIKROPOR*
- *MIKROPUL*
- *MONROE ENVIRONMENTAL*
- *MPF*
- *NAFCO*
- *NAPA*

- *NEDERMAN*
- *NEW YORK BLOWER*
- *NORDSON*
- *NUGENT*
- *OSPREY*
- *PALL*
- *PANGBORN*
- *PAULI SYSTEMS*
- *PAXTON*
- *PECO*
- *PEERLESS*
- *PENN STATE INDUSTRIES*
- *PHOENIX FILTRATION*
- *PIOVAN*
- *PLYMOVENT*
- *PNEUMAFIL*
- *POLARIS*
- *POWER BOSS*
- *PROGRESSIVE BLASTING*
- *RACOR*
- *REED*
- *REFILCO*
- *ROBOVENT*
- *ROSS*
- *ROYAL*
- *ROYAL FILTER*
- *ROYAL FILTERMIST*
- *SAITY METCO*
- *SAITY METRO*
- *SCIENTIFIC*
- *SEMCO*
- *SIEMENS*
- *SLY*
- *SNOW*
- *SOLBERG*
- *SONIC BLOWER*

- SPARKS
- SPITZER
- STANDARD
- STEELCRAFT
- STEPHENS
- STODDARD
- SULLAIR
- SUNSHINE
- SWITCH FILTRATION
- TDC
- TENNANT
- TEREX JOHNSON ROSS
- TEXAS FILTRATION
- TIPTON
- TORIT
- TRION
- TVS
- UAS
- ULTRA
- UNITED ENGINE LIFE
- UNIVERSAL SILENCER
- UNIWASH
- US AIR FILTRATION
- VAC U MAX
- VELCON
- VIKING
- VILEDON
- WAGNER
- WAM
- WAUKESHA
- WHEELABRATOR
- WHITE SUPERIOR
- WHITLOCK
- WHITNEY
- WIX
- ZEPHYR

- **Busch Filters**
- **Mann & Hummel Air Filters**
- **Conair Filters**
- **McQuay Filters**
- **Baldwin Filters**
- **CUNO Water Filters**
- **Dollinger Filters**
- **Pall Hydraulic Filters**
- **Solberg Air Filters**
- **Stoddard Silencer Filters**
- **Grainger Air Filters**
- **Heidelberg Filters**
- **Universal Silencer Filters**
- **Ingersoll Rand Air Filters**
- **Becker Pump Filters**
- **Keltec Filters**
- **Liquid Bag Filters**
- **Air Handler filters**
- **Aeolus**
- **Aircon**
- **Air Flow Technology**
- **Airflow Products**
- **Airflow Systems**
- **Airguard**
- **Barneby & Sutcliffe**
- **BHA**
- **Cambridge**
- **Chemco**
- **Columbus Industries**
- **Consler/Graver**
- **Continental**
- **CSC**

- **Duralast**
- **Industrial**
- **Endustra**
- **Environmental Filter Corp**
- **Facet**
- **Farr**
- **Fiberbond**
- **Filter Mart**
- **Filtration Group**
- **Flanders**
- **Flanders / Precisionaire**
- **Glasfloss**
- **Hefco**
- **HEPA Corp**
- **Koch**
- **MicroAir**
- **Parker**
- **PECO**
- **Purafil**
- **Purolator**
- **Quality Filters**
- **Research Products**
- **Royal Filters**
- **RSE**
- **Servodyne**
- **Shawndra**
- **Smith**
- **Sparks**
- **Swift**
- **TDC**
- **Tri-Dim**
- **Viledon**

- **Aercology**
- **Donaldson**
- **Ingersol Rand**
- **NAFCO**
- **Sunshine**
- **Filpro**
- **Filter All**

- **AAF**
- **ABSOLENT**
- **AC DELCO**
- **AERCOLOGY**
- **AEROSTAR**

- **AIR MAZE**
- **AIR PANEL**
- **AIRCLEAN SYSTEMS**
- **AIRFLOW PRODUCTS**
- **AIRFLOW SYSTEMS**
- **AIRGUARD**
- **AIRSAN**
- **ALUMINUM FILTER**
- **ALUMINUM MESH PANEL**
- **ATLAS COPCO**
- **BUNN**
- **BURGESS-MANNING**
- **CAMERON**
- **CAMFIL FARR**
- **CARBON FILTER**
- **CHICAGO CFM**
- **CHICAGO PNEUMATIC**

- CLARK
- COMPAIR
- COMPAIR-LEROI
- COMPLETE FILTRATION
- CONSLER
- COOPER
- DIVERSIFIED AIR
- DOLLINGER
- DONALDSON
- DONALDSON TORIT
- ELLIOTT
- EMAG
- ENDUSTRA
- EUCLID
- EZ KLEEN
- FARR
- FILPRO
- FLAMEGARD
- FLANDERS
- FLEETLIFE
- FLUITEK
- FORD
- FORECAST SALES
- FRAM
- FUMEX
- GENERAL ELECTRIC
- GLASFLOSS
- GMC
- GRAINGER \ HALCO
- HERTZ KOMPRESSION
- HOFFMAN
- HONEYWELL

- IFM
- INDUSTRIAL MAID
- INGERSOLL RAND
- JOY
- KEMP
- KOCH
- KOCH FILTER
- KOMATSU
- LEROI
- LUBERFINER
- MCMASTER-CARR
- MIKROPOR
- MOTION
- MOTION INDUSTRIES
- MOTORCRAFT
- NAFCO
- NAPA
- NEWARK
- NORDSON
- ORANGE AND WHITE
- PAD HOLDING FRAME
- PANEL FILTER
- PLEATED AIR FILTER
- PLEATED PANEL
- PLEATED PAPER
- POLY PAD
- POLY PANEL
- PUROLATOR
- QUINCY
- ROTRON
- SCHMIDT
- SHAWNDRA
- SOLAR

- SOLAR TURBINE
- STANDARD CAP HEPA
- STODDARD
- TENNANT
- TORIT

- TRANE
- TRION
- TROX
- UNIVERSAL SILENCER
- US AIR COMPRESSOR
- US TURBINE
- VILEDON
- WAUKESHA WHEELABRTOR